

SR5

nI-NL Montagehandleiding

Inhoudsopgave

Voor het starten	3	Voertuiginterieur verbinden	103
Persoonlijke configuratie	4	Toebehoren monteren	106
Tussenaanzicht	4	Uitschuifgeleider boven	106
Bovenaanzicht op SoboPro	5	Uitschuifgeleider onder	107
Totaalaanzicht	5	Uitschuifgeleider onder 04-0 FB03 . .	108
SoboPro monteren	6	Uitschuifgeleider onder en boven . .	109
Profielen voorbereiden	9	Verdeelschot voor legbord	110
Componenten bevestigen . .	14	Verdeelschot voor legbord met rand	111
Stabiliteitscriteria	15	Legbord universele kast	112
Draaiblok 90° T4/T5	73	Werkblad voor legbord	113
90° T7 twee richtingen blok	81	Montage van de accessoires voor het zijprofiel	114
Verbindingsstappen begrijpen	89	Logo	114
EcoFIX — Wat is dat?	89	Aflegvak	115
EcoFIX aan het voertuiginterieur verbinden	90	Aflegvak voor papieren	116
Achterwandprofiel bevestigen	94	Papierhanddoek dispenser	117
Achterwandprofiel uitbreiden	97	ProSafe vastzetrail	118
EcoFIX aan de voertuigwand verbinden	100	Hakenstrip	119
Aantal en positie bepalen	102	Slangenhouder	120
		i-BOXX wandhouder	121
		Handgreep	122

Tussenprofielaccessoires
monteren 124

- Aflegvak 124
- Aflegvak voor papier 125
- Papierrolhouder 126
- Montagerail ProSafe 127
- Hakenstrip 128
- Slanghouder 129
- i-BOXX-wandhouder 130

Voor het starten



WAARSCHUWING

Ietsel door het tillen van een te zware last

De kast kan te zwaar zijn voor één persoon, afhankelijk van de configuratie. Dit kan licht ietsel veroorzaken.

- Montage moet door twee personen worden uitgevoerd.

Aanbeveling

Afhankelijk van de configuratie, zijn er meer kasten in de aflevering inbegrepen. We raden u aan om deze afzonderlijk van elkaar te monteren.

Werkplek

Zorg voor een veilige werkomgeving. Plaats het voertuig op een vlakke, stevige ondergrond.

Schroefvergrendeling

Als er met het voertuig op onverharde wegen wordt gereden, moeten alle schroefverbindingen worden bevestigd met een geschikte schroefvergrendeling.

Toegankelijkheid service materialen

Als u de bedrijfswageninrichting installeert, zorg er dan voor dat alle al aanwezige hulpmaterialen (bijv. EHBO trommel, reservewiel) goed toegankelijk blijven.

Aanhaalmomenten

Zorg ervoor dat u voldoet aan de gespecificeerde aanhaalmomenten en hun toleranties.

- a) Standaard schroefaansluiting

Draadafmeting	Aanhaalmoment
M5	4 Nm \pm 10%
M6	7,5 Nm \pm 10%
M8	20 Nm \pm 10%

- b) Speciale bevestigingsmiddelen met schroefdraad

Bevestigingsmiddel met schroefdraad	Aanhaalmoment
Plastic geleiders op de onderkant	7.0 Nm \pm 0.5 Nm
Trek de rail onder en boven naar buiten	4.5 Nm \pm 0.5 Nm
Accessoires voor zijprofiel	4.5 Nm 1.0 Nm
Veldverdeling in frame	4.5 Nm \pm 0.5 Nm
Veldonderverdeling in zijprofiel	5.5 Nm \pm 0.5 Nm
Veldverdeling in vakkenrek	8.5 Nm \pm 1.0 Nm

Bovenaanzicht op SoboPro

Deze weergave toont de SoboPro, de zijprofielen en de tussenprofielen van boven gezien. De zij- en tussenprofielen zijn eenduidig gekenmerkt. Bovendien bevat deze weergave de hoogtegegevens van de afzonderlijke zij- en tussenprofielen.

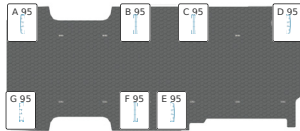

Informatie over de afzonderlijke profielen:

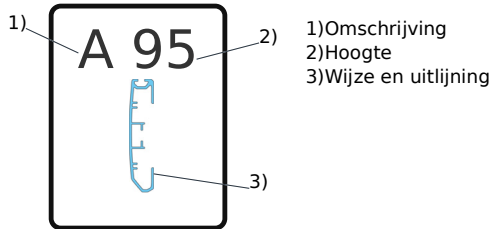

Totaalaanzicht

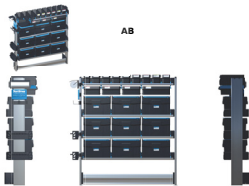

Het totaalaanzicht toont uw voertuiginrichting aan elke zijde en in de isometrie. Elk veld wordt apart weergegeven. De omschrijving van het veld wordt afgeleid uit het betreffende profielpaar.

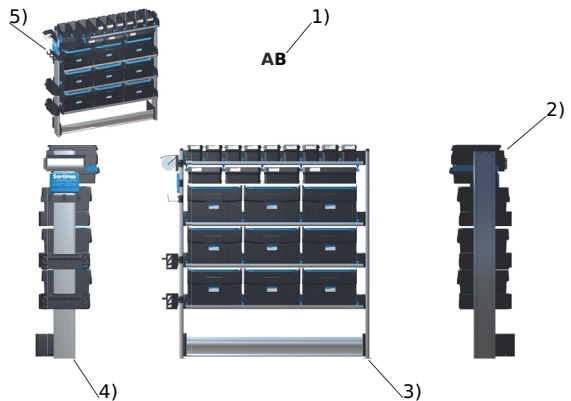

- 1) Omschrijving veld
- 2) Zijaanzicht rechts
- 3) Vooraanzicht
- 4) Zijaanzicht links
- 5) Isometrisch aanzicht

SoboPro monteren

OPGELET

Materiële schade door slechte hantering.

De verbindingsvouwen in de bodemplaten zijn gevoelig voor stoten en knellen.

- ▶ Verbind de bodemplaten voorzichtig.

Stap 1 — Voertuig voorbereiden

Opmerking: Als uw voertuig een bodembekleding heeft, moet deze worden losgehaald.

- ▶ Verwijder sjourgen in de bodem.

Opmerking: Houd de onderdelen van de gedemonteerde sjourgen apart voor latere montage.

- ▶ Reinig de voertuigbodem.

Stap 2 — Bodemplaten plaatsen

- ▶ Controleer of de vouwen in de bodemplaten beschadigd zijn.
- ▶ Plaats de eerste bodemplaat.

Opmerking: De legrichting is vanaf de scheidingswand naar de achterkant van het voertuig.



- ▶ Plaats de volgende bodemplaat.
- ▶ Voeg de bodemplaten samen.

Opmerking:

- De verbindingseinden moeten vlak zijn.
- De uitsparingen moeten gelijk zijn aan de afdekking.

- ▶ Plaats indien beschikbaar de volgende bodemplaten na elkaar en verbind ze met de vorige.

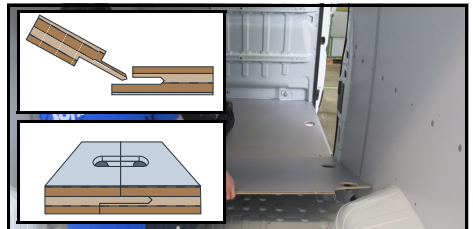

Stap 3 – Vloerklemmen bevestigen

- ▶ Plaats de vloerklemmen.
- ▶ Bevestig de vloerklemmen voorzichtig met een rubberen hamer.
- ▶ Herhaal de handelingen totdat alle vloerplaten met elkaar zijn verbonden.

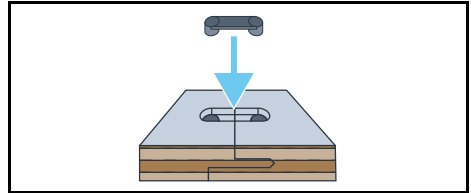

Stap 4 – Vloerplaten uitlijnen

- ▶ Gemonteerde vloerplaat uitlijnen.

Opmerking: De vloer moet in alle richtingen van de voertuigcarrosserie dezelfde afstand hebben tot de bodemplaten. De volgende elementen geven hulposities:

- bevestigingspunten,
- wielkasten.

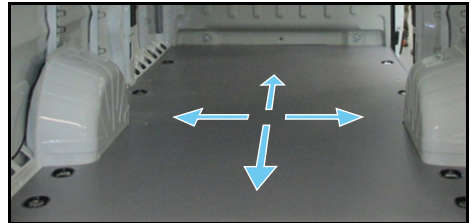

Stap 5 — Sjorogen bevestigen

- ▶ Bevestig de sjorogen met de oorspronkelijke schroeven op de oorspronkelijke posities.

Opmerking: Door de bodemplaat is inbouw van een montagerail nodig. Afhankelijk van de vloer van de voertuigcarrosserie moet de montagerail met sluitringen worden verhoogd.

- ▶ Bepaal het aantal sluitringen.

Opmerking: Het aantal moet zo worden gekozen, dat de vloerplaat licht wordt aangedrukt.

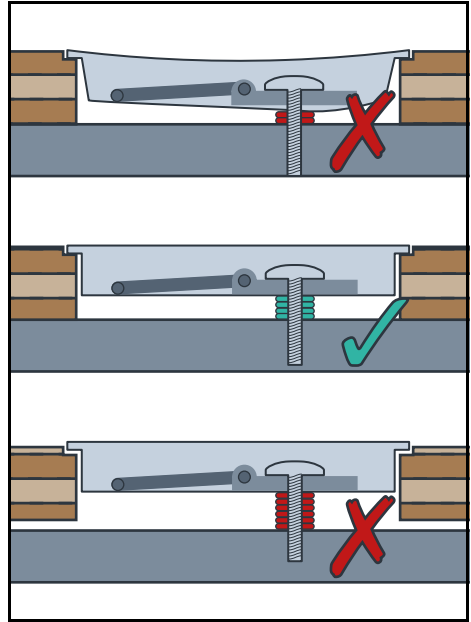

- ▶ Haal de oorspronkelijke schroeven aan met het vereiste aanhaalmoment.

Opmerking: U vindt het betreffende aanhaalmoment in de richtlijnen van de carrosseriefabrikant.

Profielen voorbereiden

Stap 1 – Profielvoeten toewijzen

Opmerking: Er zijn drie verschillende soorten profielvoeten. Het aantal en het type profielvoeten is afhankelijk van uw configuratie.

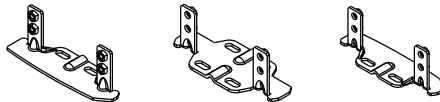

- Wijs aan elk zijprofiel/tussenprofiel de bijbehorende profielvoet toe.

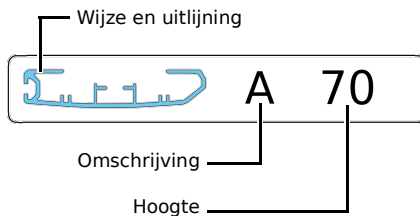

Stap 2 – Profielvoeten fixeren



► Fixeer de profielvoet aan het profiel.

1

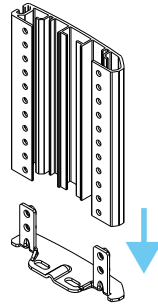

2

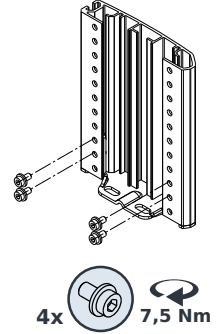

Stap 2 — Profielvoeten fixeren



- Fixeer de profielvoet op de SoboPro.

3

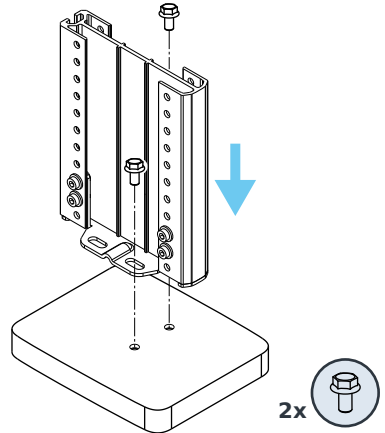
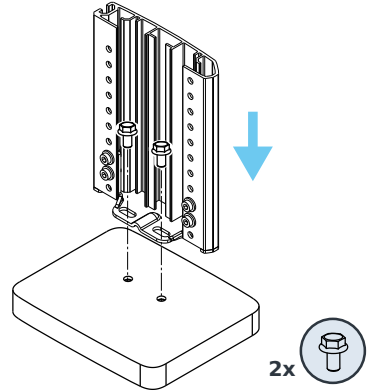

- Herhaal de handelingen totdat alle profielvoeten zijn gefixeerd.

Stap 3 — Inbouwadapter plaatsen

- Bepaal de positie.

Opmerking: De bijgevoegde Sortimo-meetlat is geschikt voor het meten van de rasterhoogte.

Opmerking: Er zijn twee verschillende inbouwadapters. Het symbool geeft aan welke inbouwadapter moet worden gebruikt.

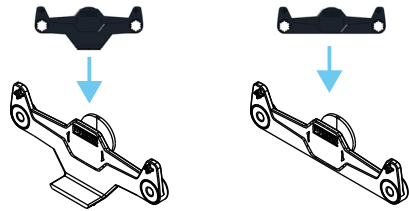

- Plaats de inbouwadapter in het profiel.

1

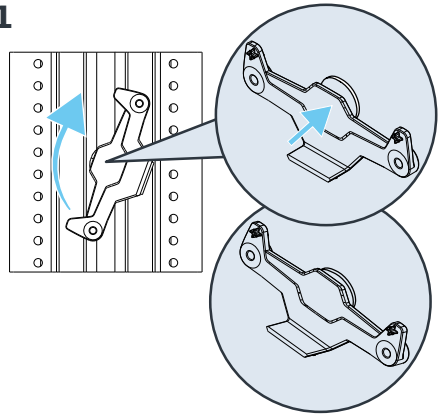

2

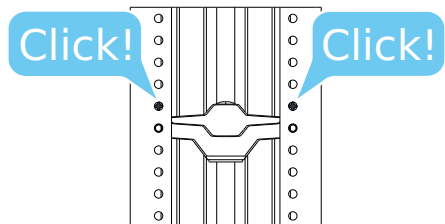

Stap 3 — Inbouwadapter plaatsen

- Plaats de inbouwadapter.

Opmerking: Door op het gedeelte "Press" te drukken, kan de inbouwadapter op de betreffende hoogte worden gepositioneerd.

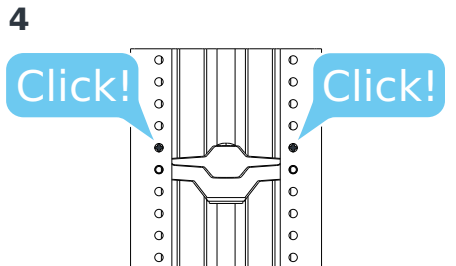
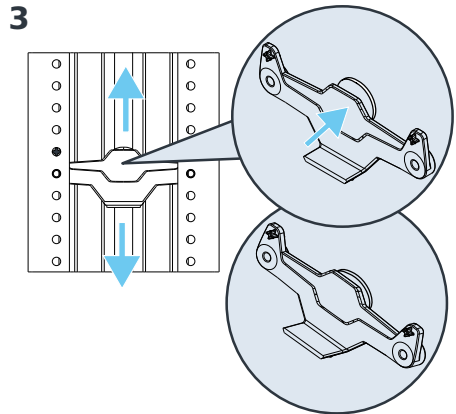

- Herhaal de handelingen totdat alle inbouwadapters zijn geplaatst.

Componenten bevestigen

Tussen de profielen zijn de volgende elementen aangebracht:

- a) Raam,
- b) Verbindingsraam
- c) Legbord
- d) Schuiflade H8/H10/H12,
- e) Schuiflade H6,
- f) SR lade
- g) MultiSlide,
- h) Veld onderverdeling,
- i) Koffer klem,
- j) Vloerfrontpaneel,
- k) Vloerfrontpaneel met vastzetrail,
- l) Vloerklep,
- m) Vloerklep met vastzetrail,
- n) Universeelkast,
- o) Opklapbare werkbank,
- p) Langmateriaalbak,
- q) Koffergeleider,
- r) Opklapbare parallelle bankschroef,
- s) Zijprofiel verticaalverbinder,
- t) Tussenprofiel verticaalverbinder,
- u) BOXX-frames,
- v) Werkblad op raam.

Hinweis: Afhankelijk van de configuratie zijn bepaalde onderdelen zijn niet inbegrepen bij de levering

Stabiliteitscriteria

De regels voor de montage van stabiliserende componenten moeten nageleefd om de stabiliteit binnen een veld te garanderen. Stabiliserende componenten omvatten:

- Legborden (legbord, open legbord met rand, vakkenrek)
- Raam
- BOXXen ramen

De configuratie van de bedrijfswageninrichting bepaalt of stabiliserende componenten nodig zijn, en zo ja, welke. De volgende elementen zijn **van cruciaal** belang:

- Schuifade
- MultiSlide
- SR lade
- Koffergeleider

Regel: Dit geldt voor de volgende regels: Met elk veld moet afzonderlijk rekening worden gehouden.

Regel A Als er meer dan twee van de bovengenoemde cruciale elementen zijn gemonteerd, moet er minimaal

- twee legborden of
- één legbord en één raam of
- één legbord en één BOXXen raam of
- één raam en één BOXX en raam

worden gemonteerd. Tevens dienen achterwandprofielen gemonteerd te worden, rekening houdend met de toegestane montagemogelijkheden van de achterwandprofielen.

Regel B: Elk van de **hierboven genoemde cruciale** elementen heeft een specifieke rasterhoogte. Als meerdere van deze elementen zijn aangebracht en de totale rasterhoogte van deze elementen gelijk is aan of hoger is dan 60, moet er minimaal

- twee ramen en één legbord of
- twee ramen en één BOXXen raam

worden gemonteerd. Tevens dienen achterwandprofielen gemonteerd te worden, rekening houdend met de toegestane montagemogelijkheden van de achterwandprofielen.

Regel C: Als er maximaal twee van de bovengenoemde **kritieke** elementen zijn gemonteerd, moet er minimaal

- twee legborden of
- één legbord en één raam of
- één legbord en één BOXXen raam of
- één raam en één BOXX en raam

worden gemonteerd. In dit geval zijn er geen achterwandprofielen nodig voor extra versteviging, op voorwaarde dat het legbord of het BOXXen raam rechtstreeks op de wand van het voertuig kan worden gemonteerd.

Verbindingsramen



- ▶ Bepaal de positie.
- ▶ Plaats het raam tussen de installatie adapters.
- ▶ Bevestig het verbindingsraam met schroeven aan de profielen.

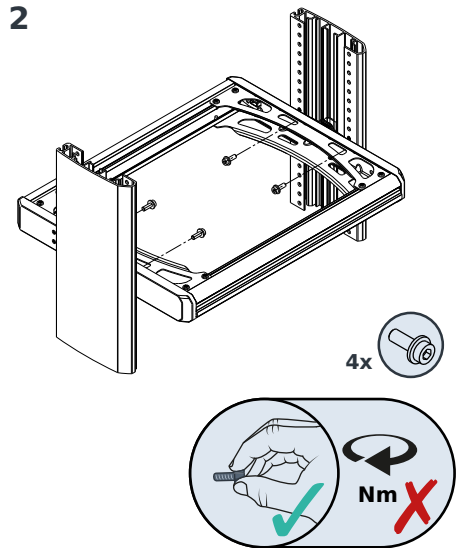
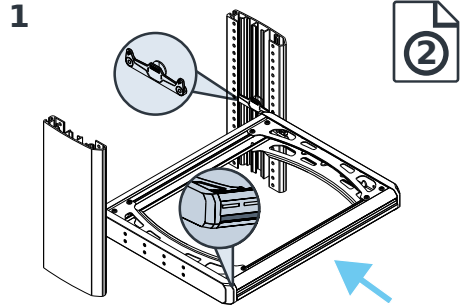

- ▶ Herhaal deze stappen totdat alle verbindingsramen zijn bevestigd.

Verbindingsramen bevestigen



- ▶ Bepaal de positie.
- ▶ Plaats het verbindingsraam tussen de installatie adapters.
- ▶ Bevestig het verbindingsraam met schroeven aan de profielen.

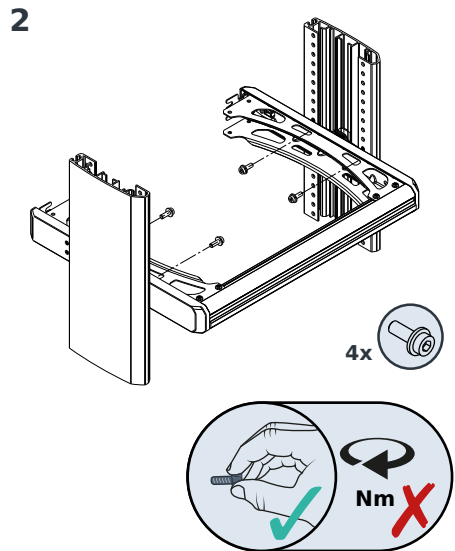
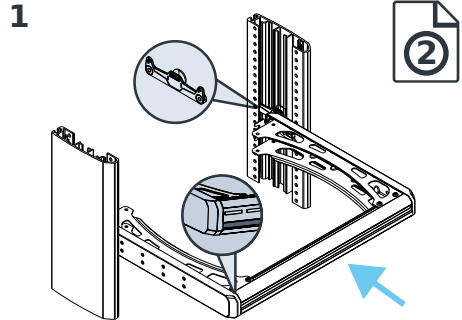

- ▶ Herhaal deze stappen totdat alle verbindingsramen zijn bevestigd.

Legborden bevestigen



- ▶ Bepaal de positie.
- ▶ Plaats het legbord tussen de installatie adapters.
- ▶ Bevestig het legbord met schroeven aan de profielen.

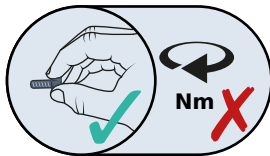
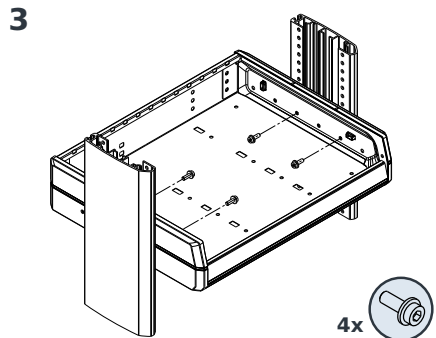
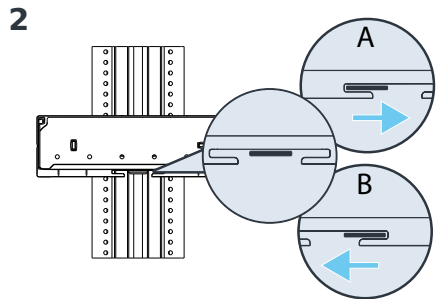
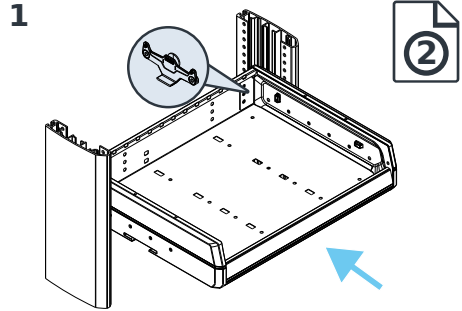

- ▶ Herhaal deze stappen totdat alle legborden zijn bevestigd.

Schuiflade H8 / H10 / H12 plaatsen

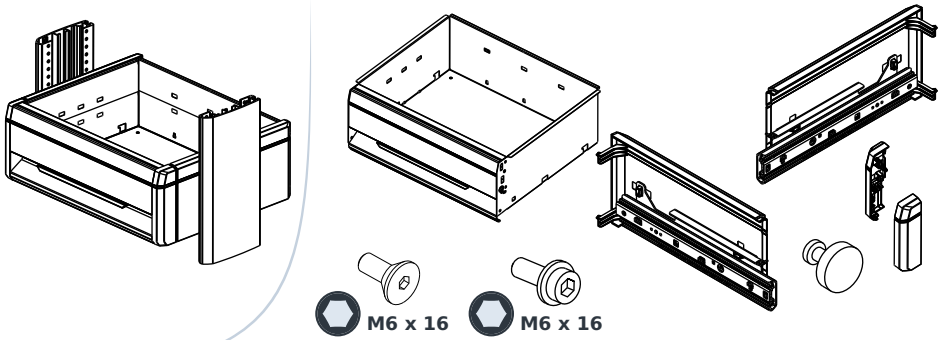

1

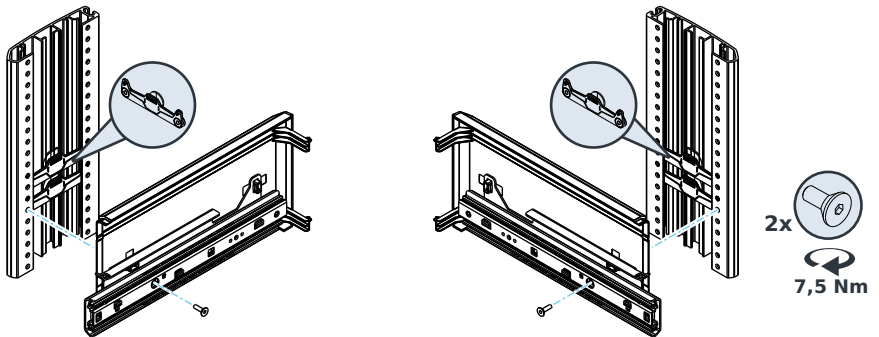

2

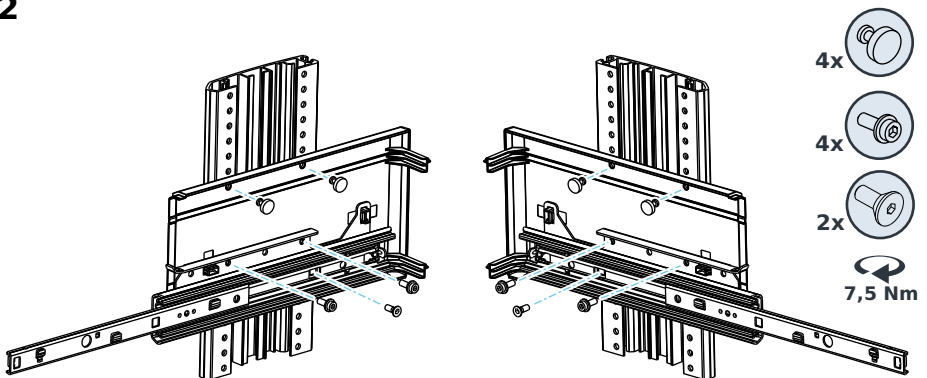

Schuiflade H8 / H10 / H12 plaatsen

3

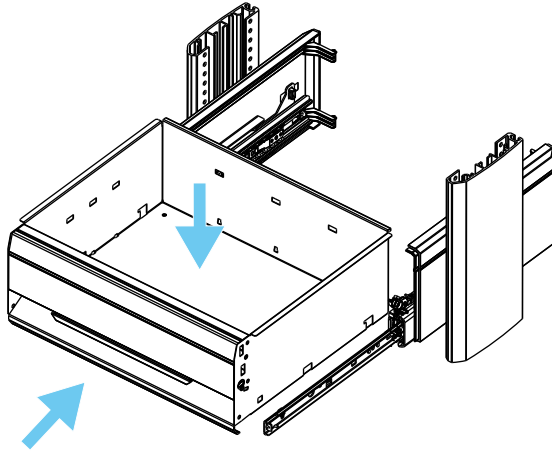

4

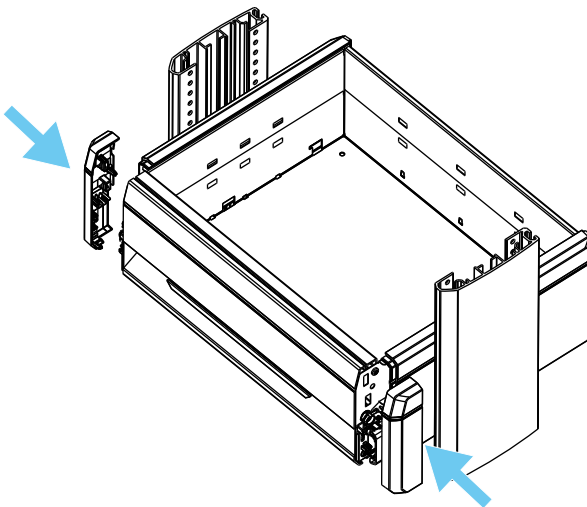

Schuiflade H6 plaatsen

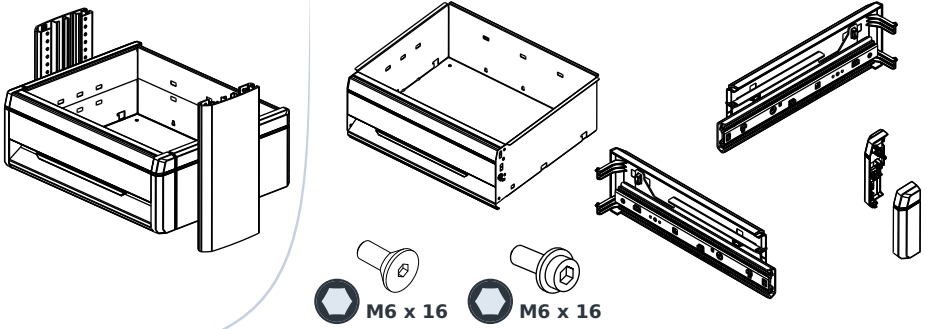

1

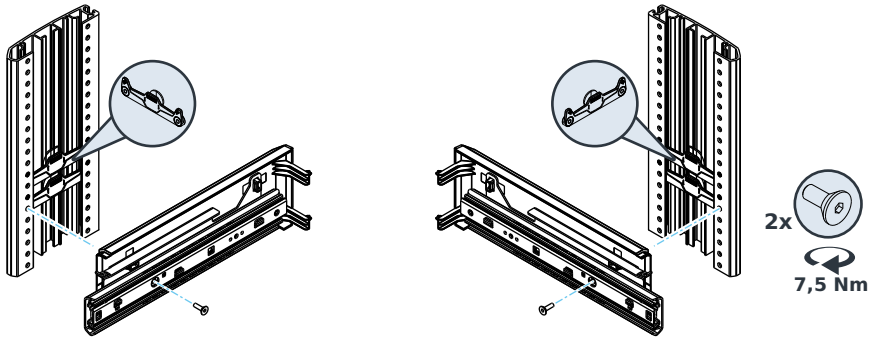

2

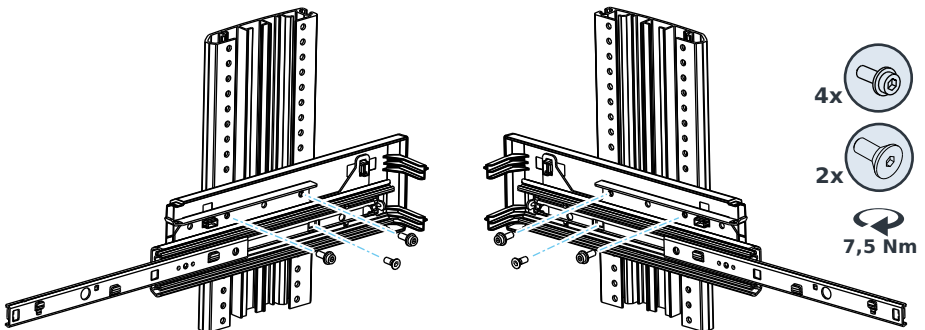

Schuiflade H6 plaatsen

3

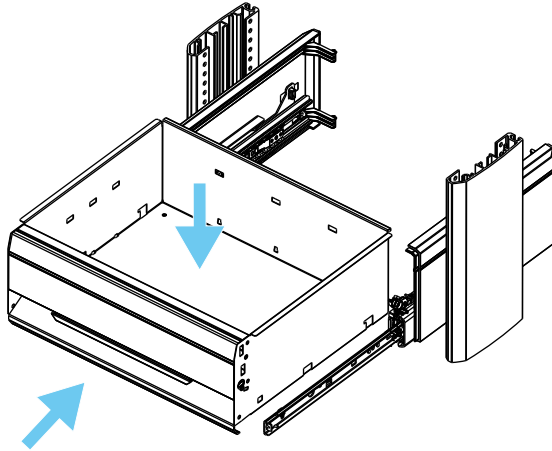

4

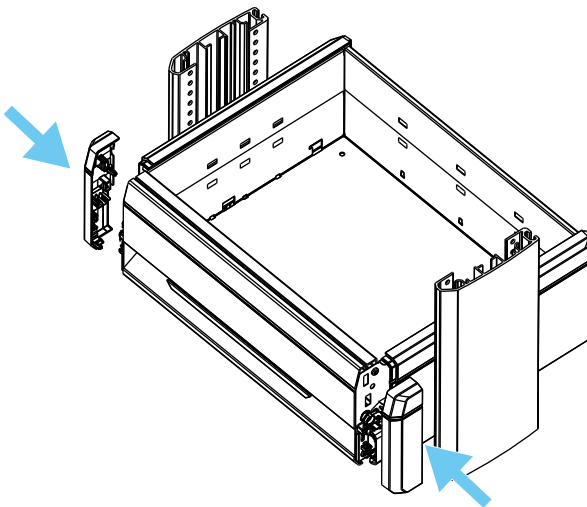

SR lade plaatsen

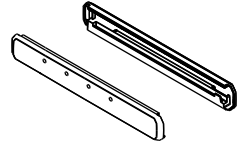
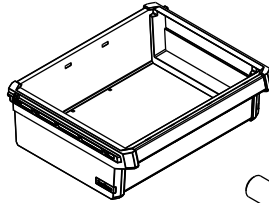
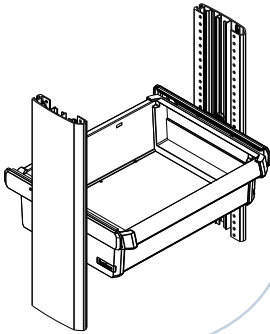

1

2

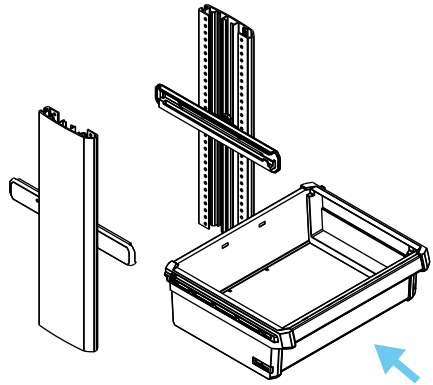
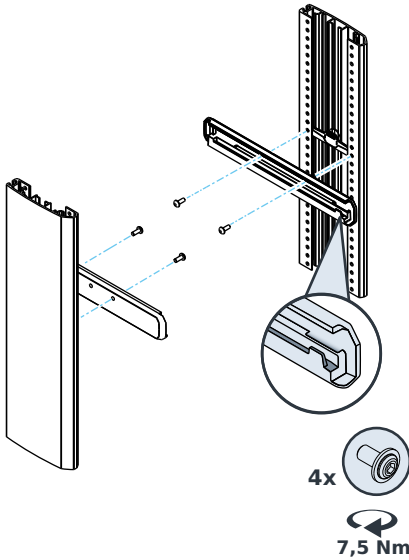

MultiSlide plaatsen

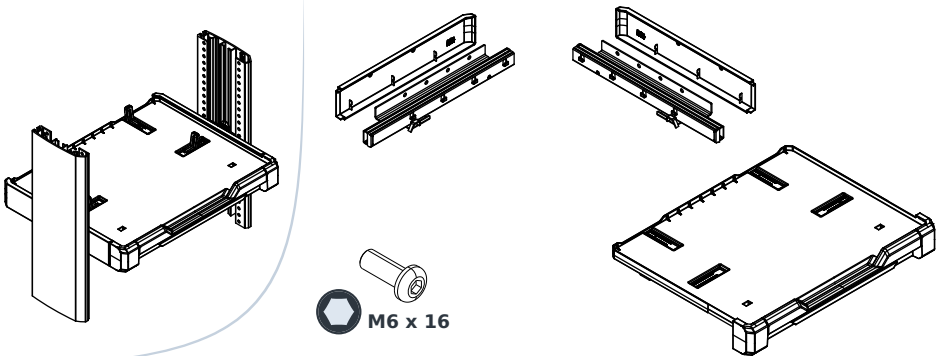

1

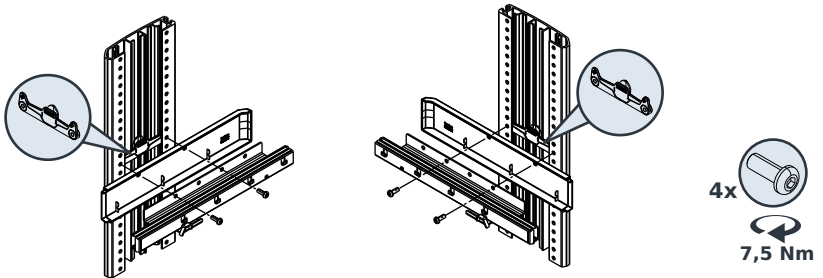

2

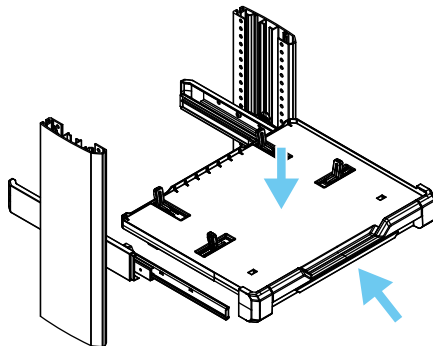

Veldonderverdelingen - raam + raam

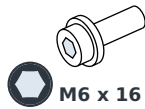
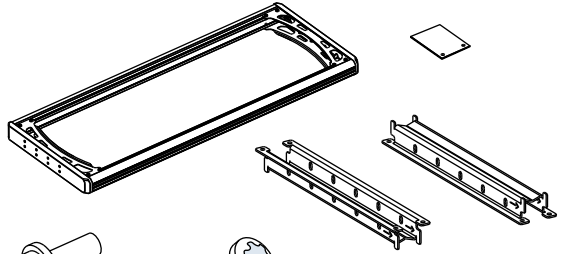
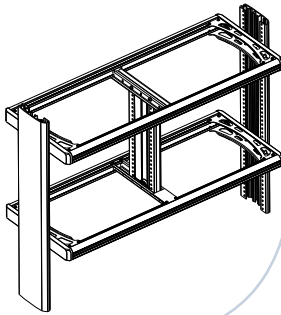

1

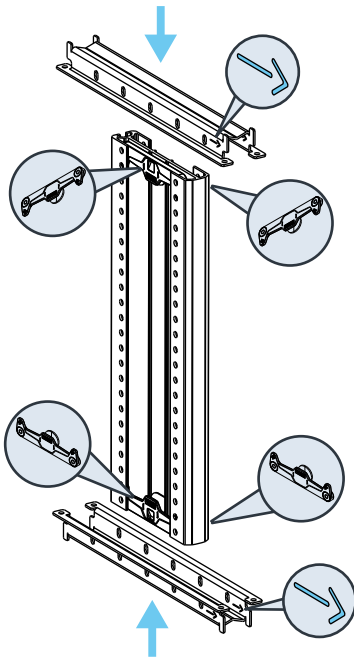

2

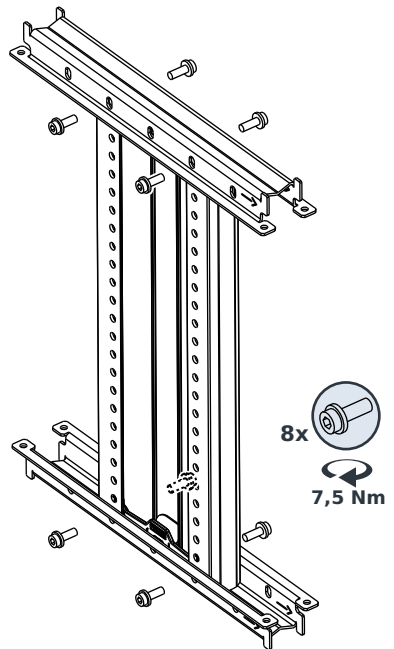

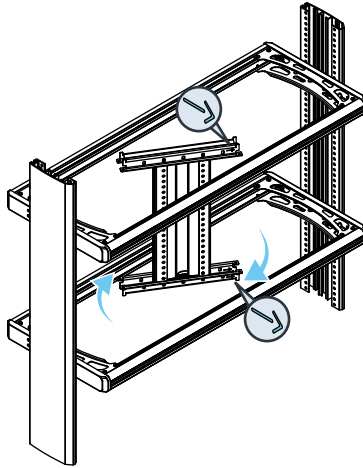

Veldonderverdelingen - raam + raam

3

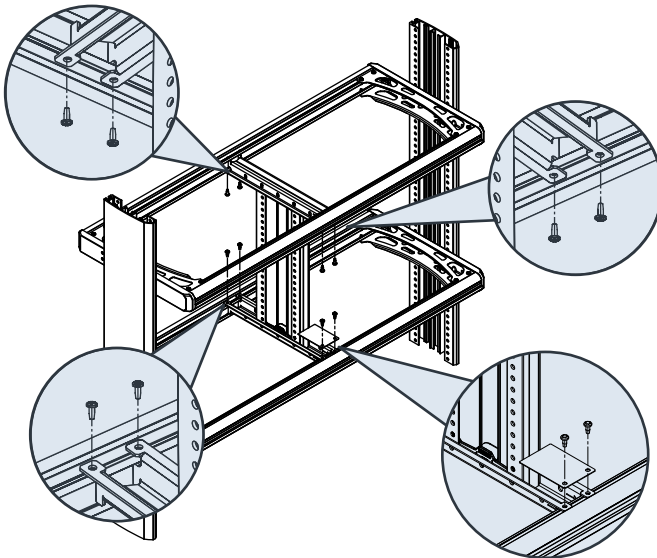

4



8x 
4,5 Nm 

Veldonderverdelingen - raam + legbord

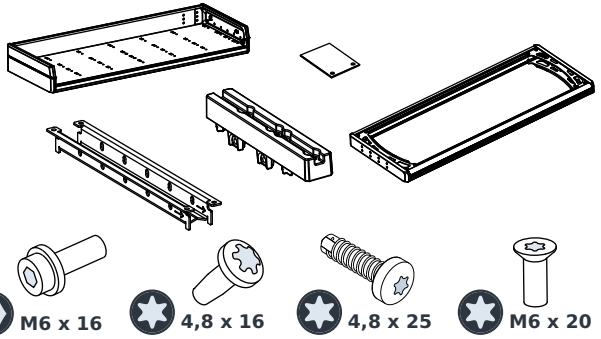
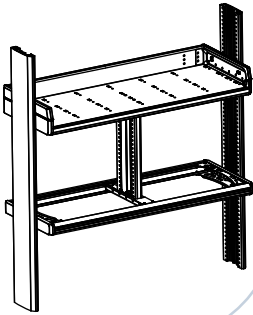

1

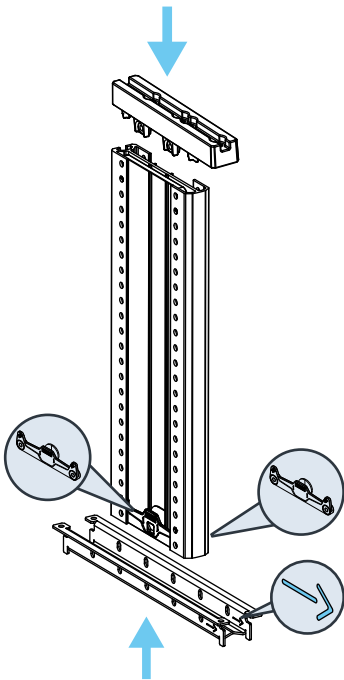

2

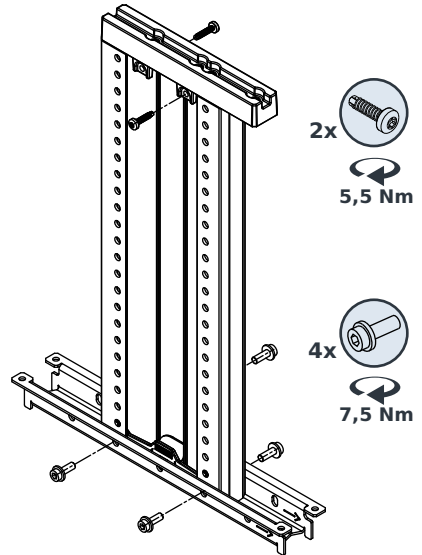

Veldonderverdelingen - raam + legbord

3

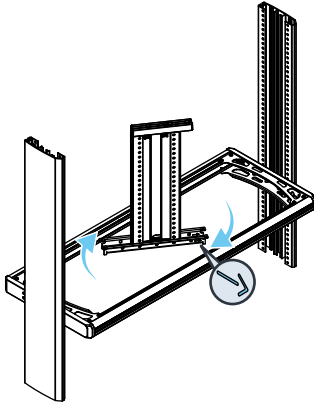

4

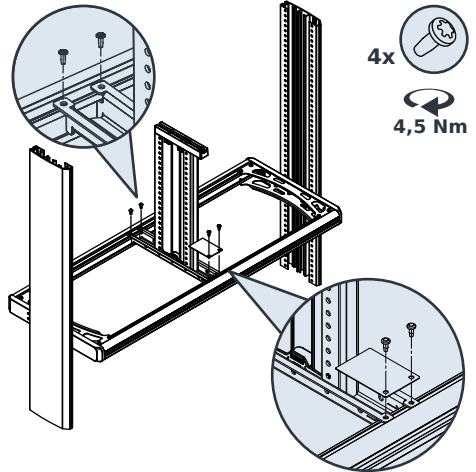

5

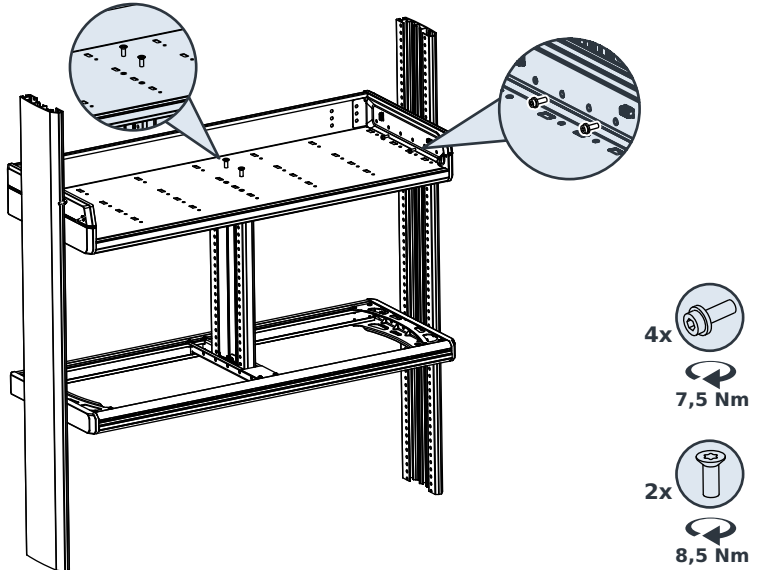

Plaatsen van de kofferklem

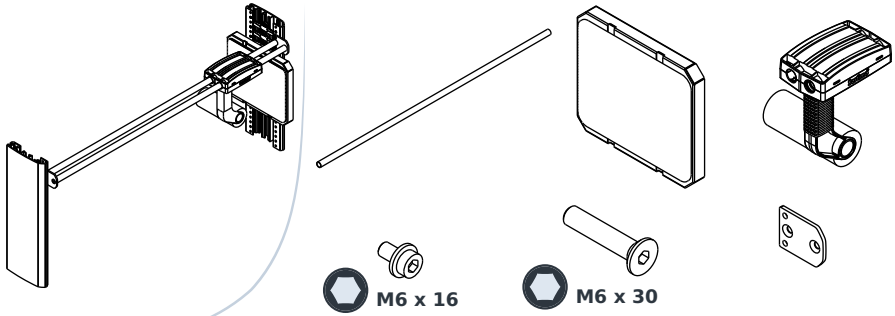

1

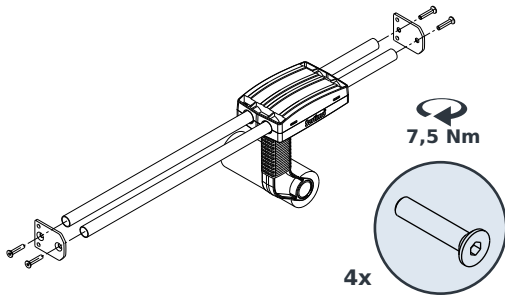

2

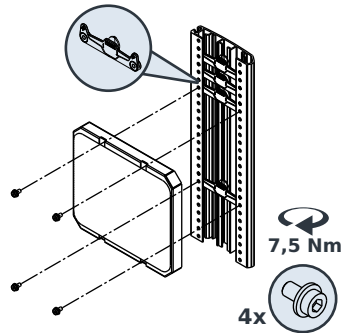

3

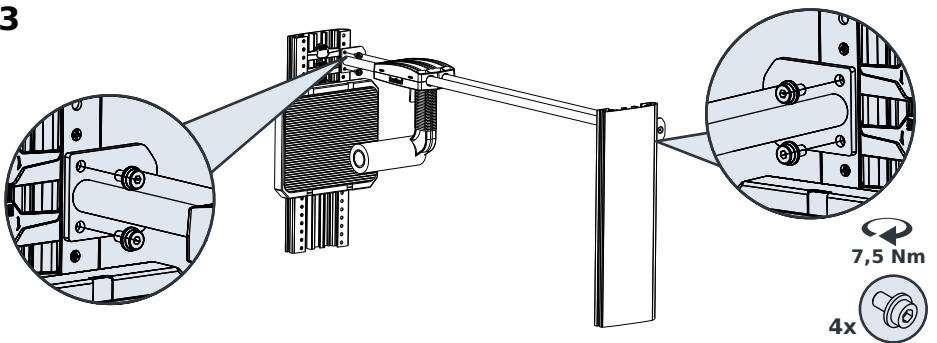

Vloerfrontpaneel

3

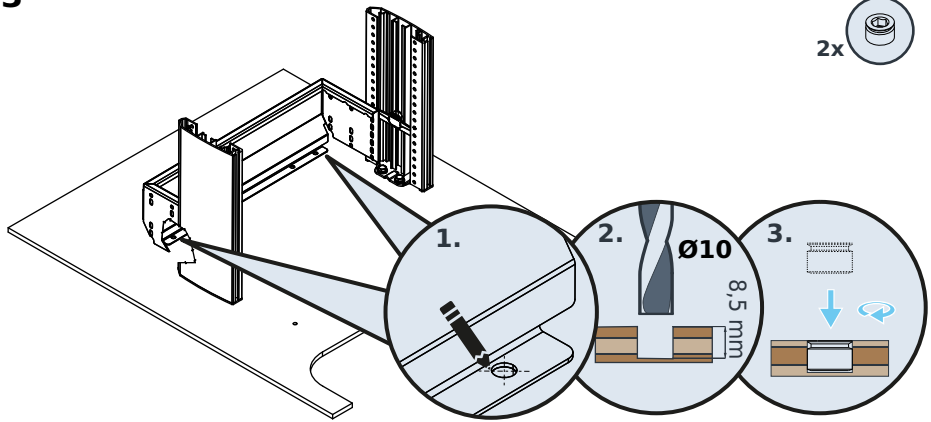

4

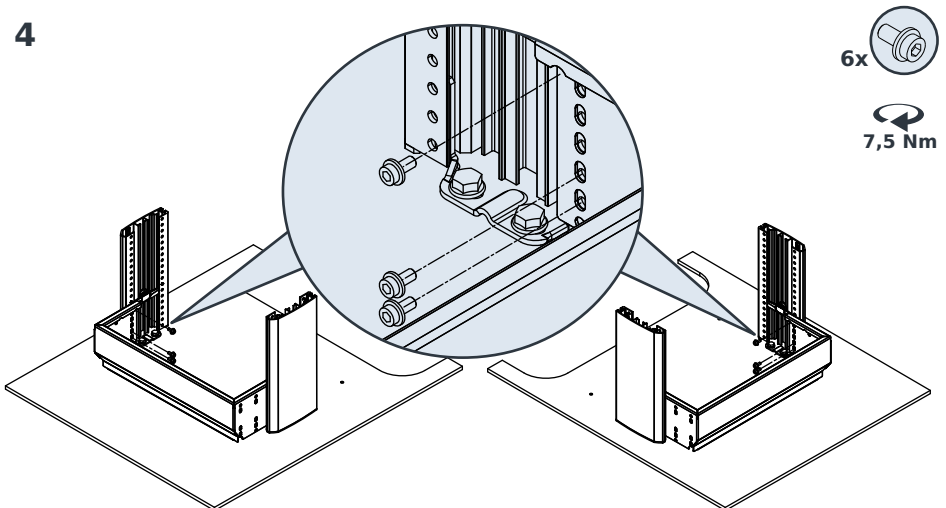

Vloerfrontpaneel

5

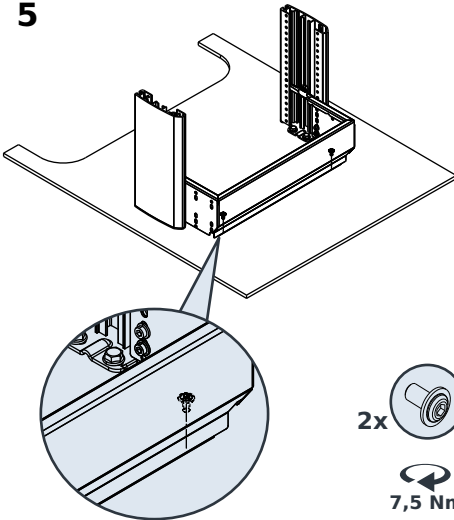

6

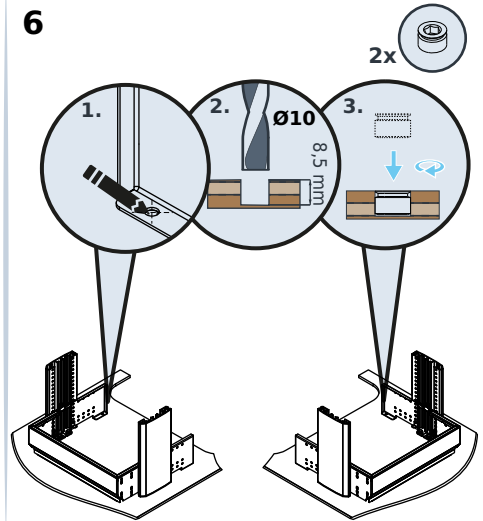

7

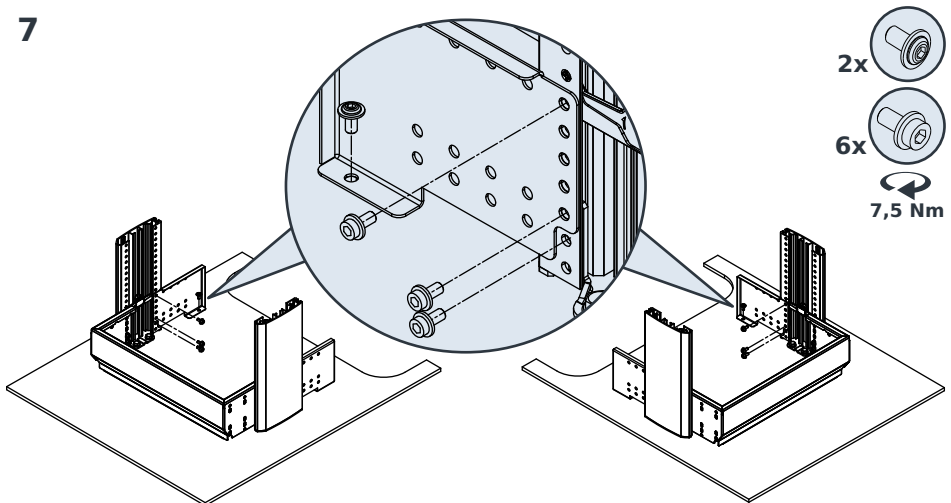

Vloerfrontpaneel met vastzetrail

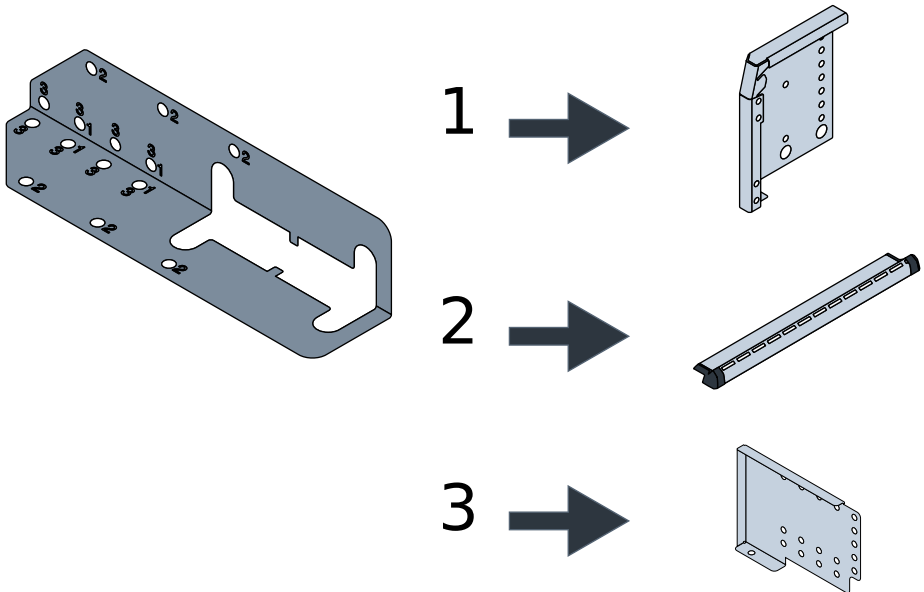
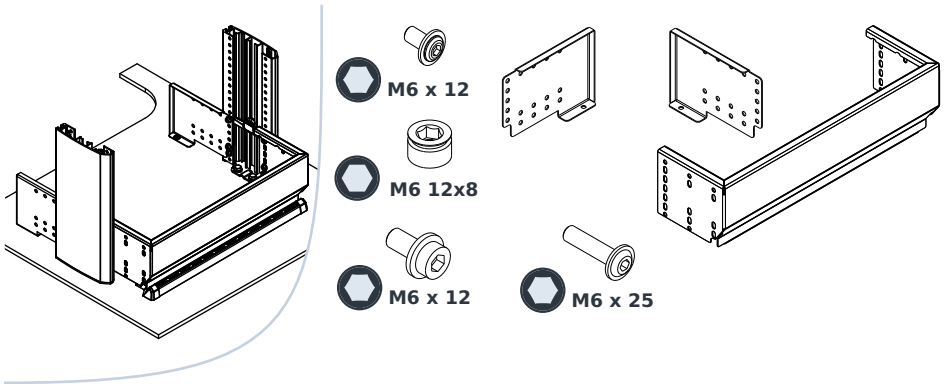

Vloerfrontpaneel met vastzetrail

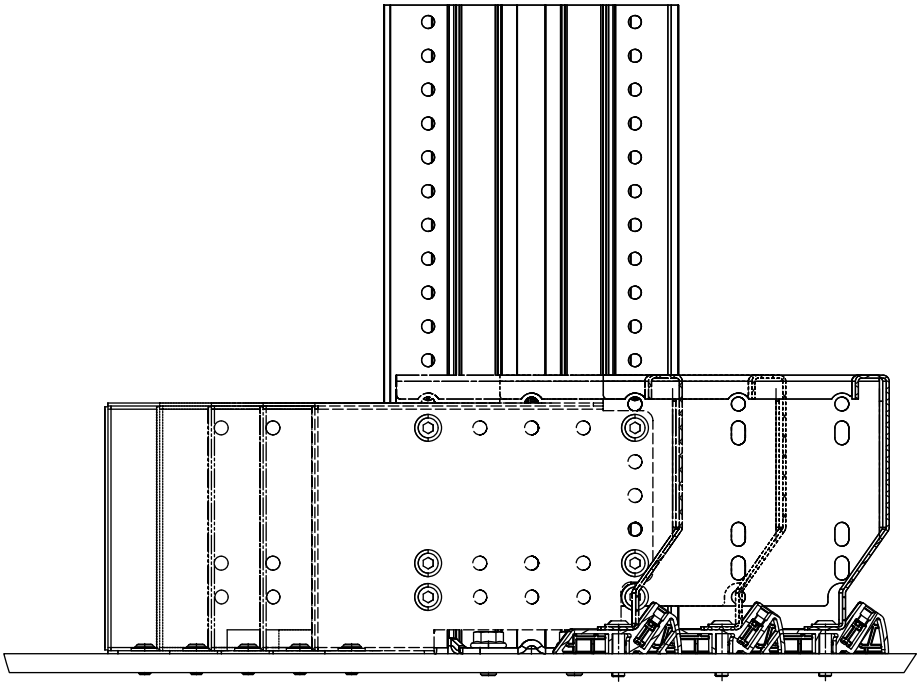

Vloerfrontpaneel met vastzetrail

1

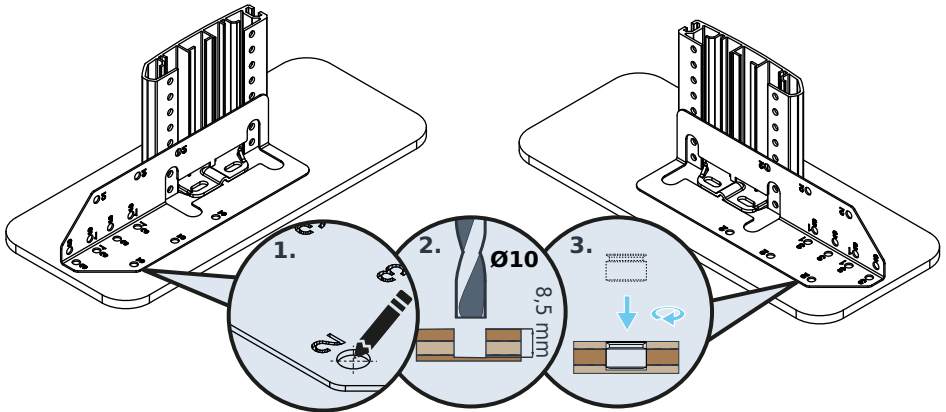

2

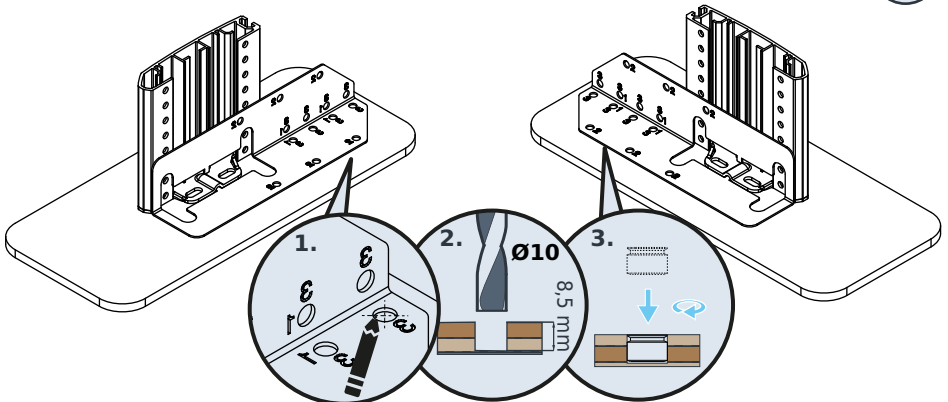

Vloerfrontpaneel met vastzetrail

3

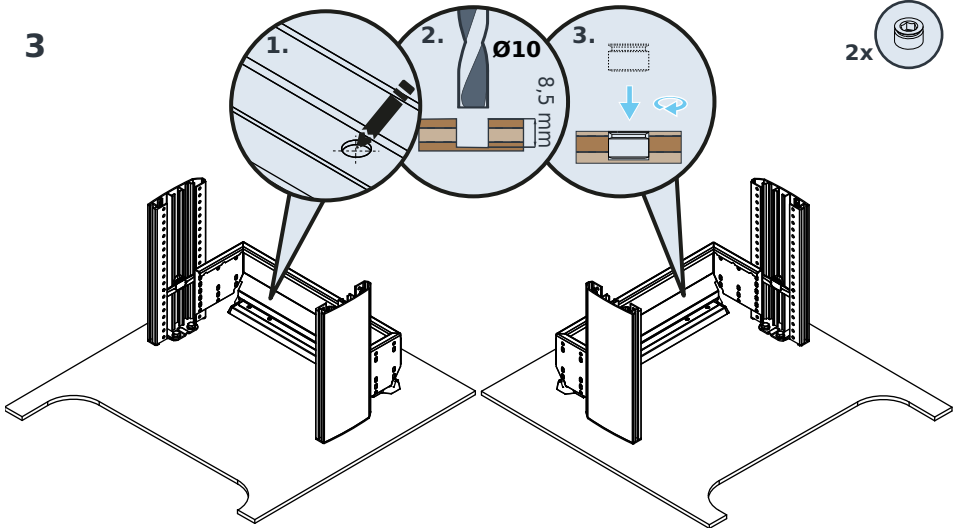

4

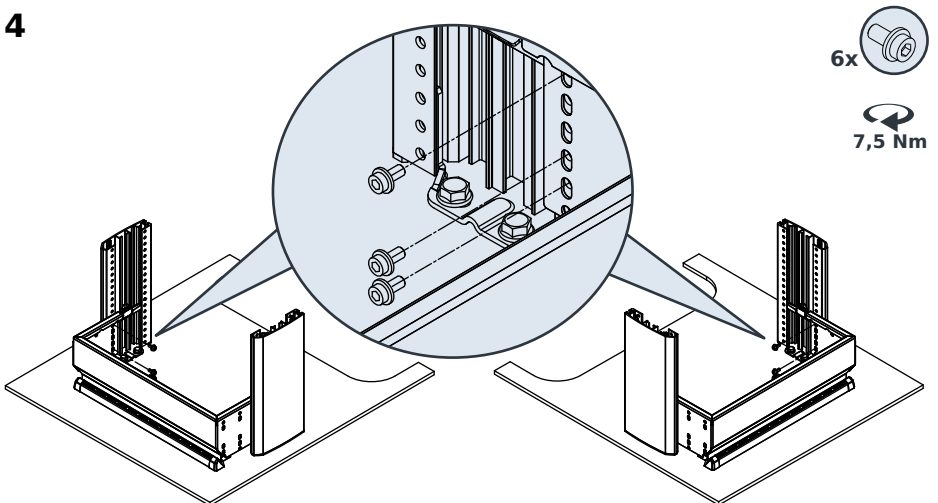

Vloerfrontpaneel met vastzetrail

5

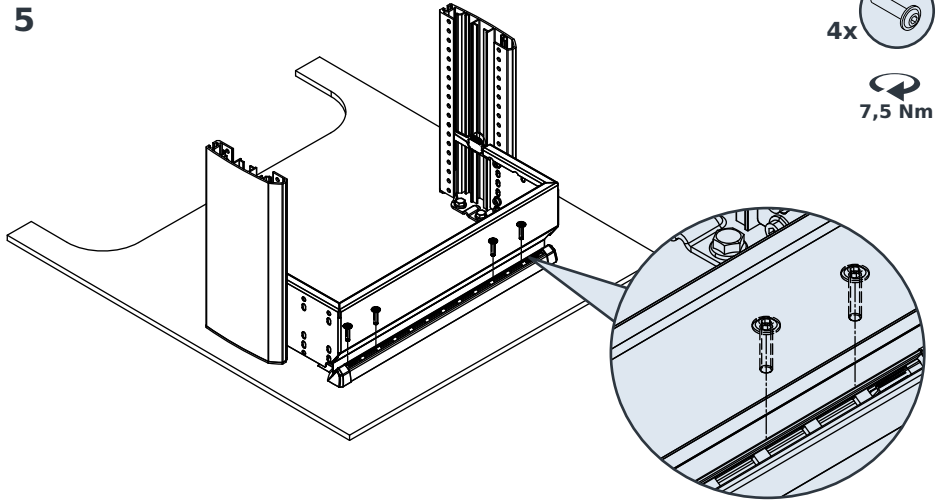

6

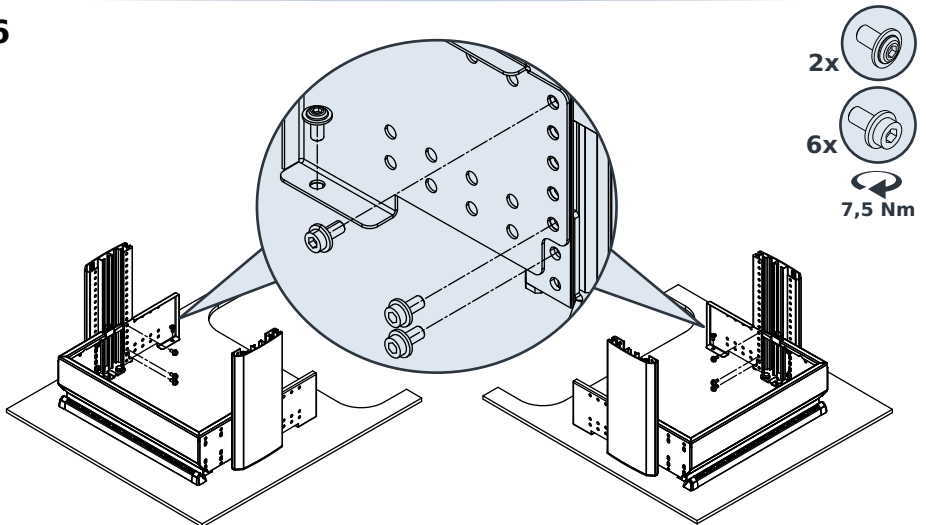

Vloerfrontpaneel met vastzetrail

20-2

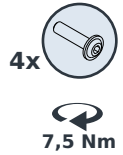
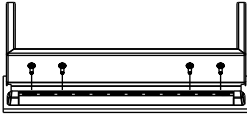

30-2

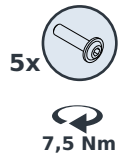
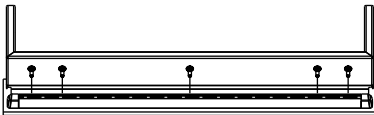

40-2

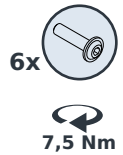
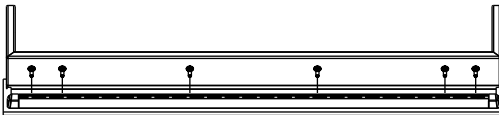

50-2

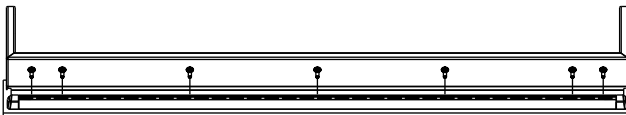

60-2

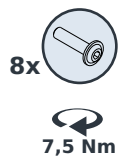

Vloerklep

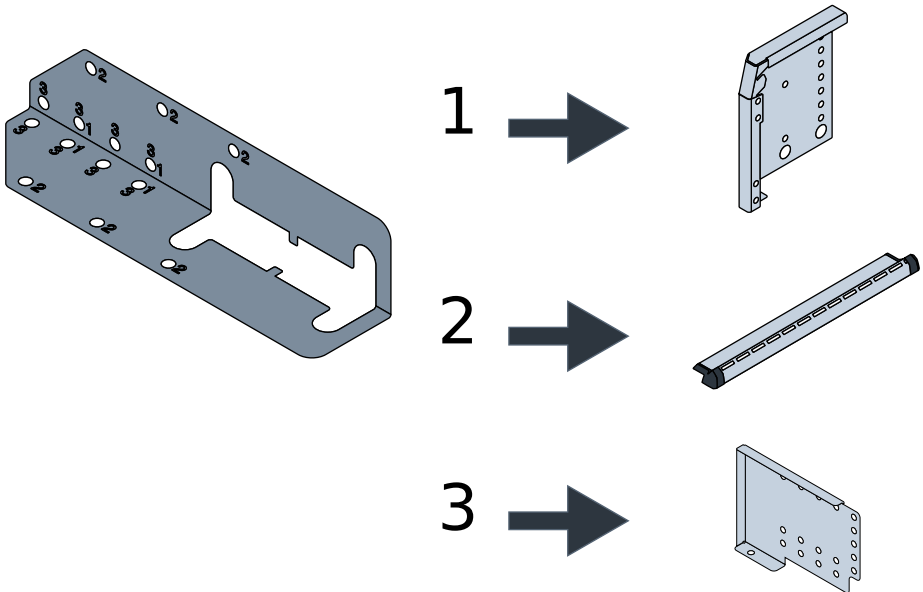
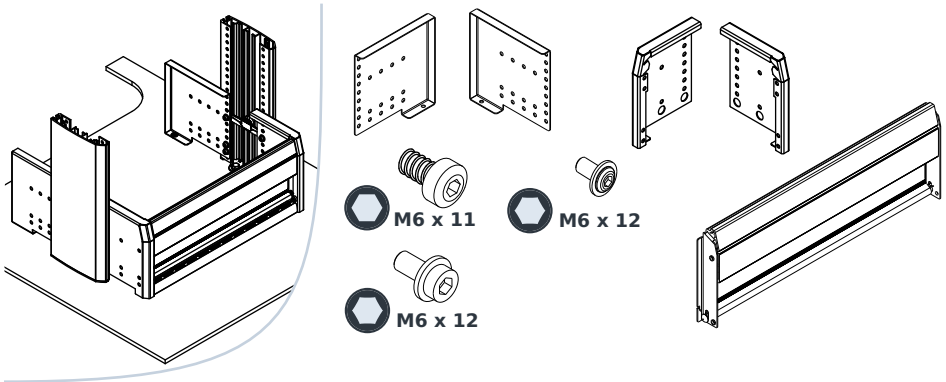

Vloerlep

1

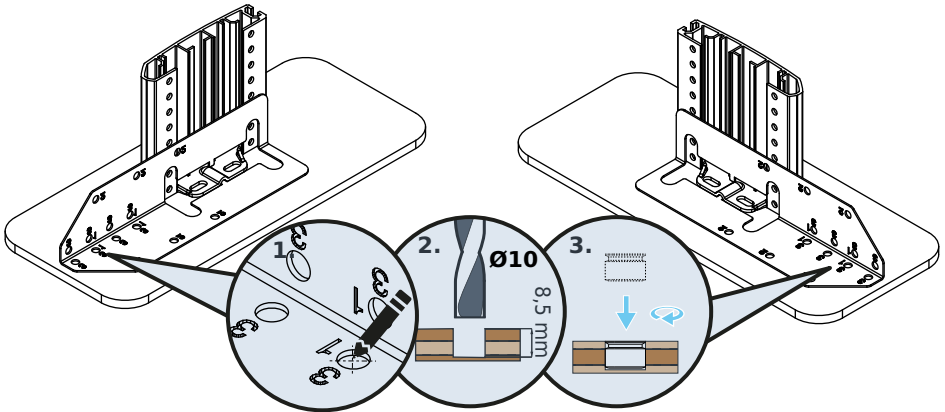

2

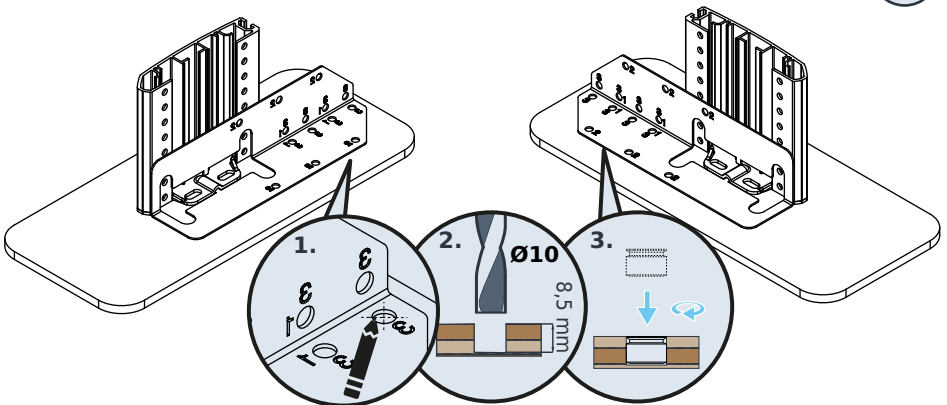

Vloerklep

3

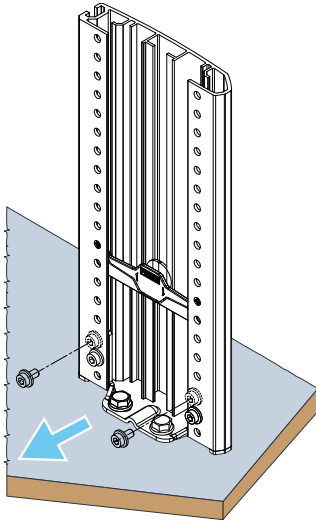

4

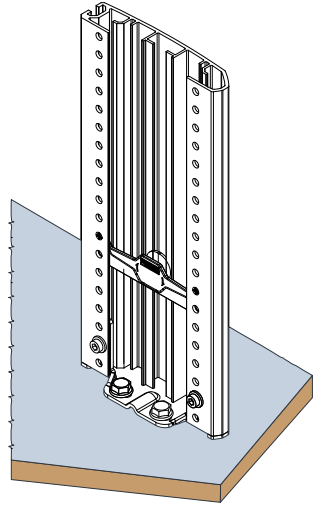

5

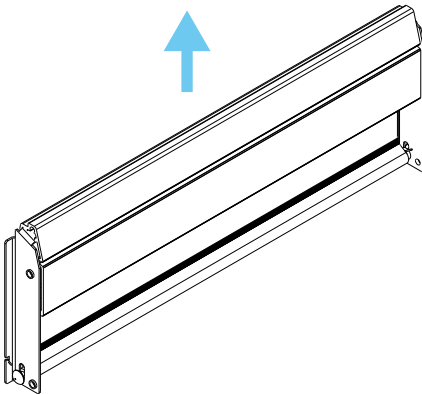

6

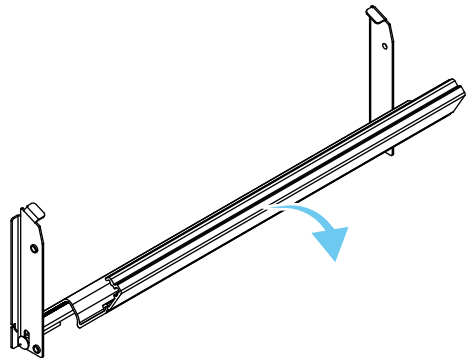

Vloerlep

7

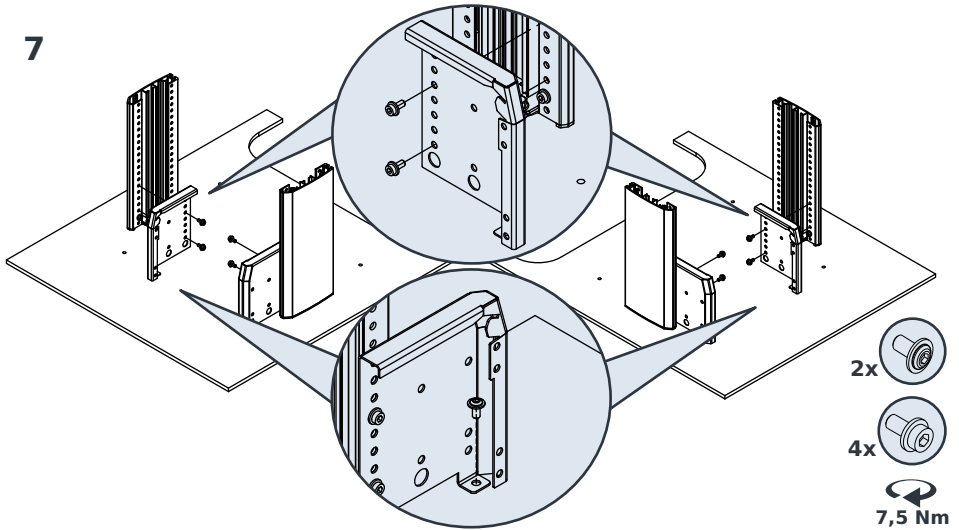

8

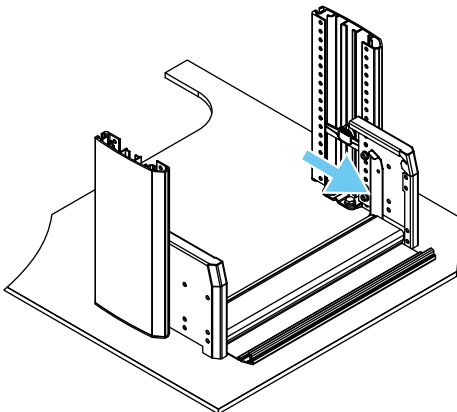

9

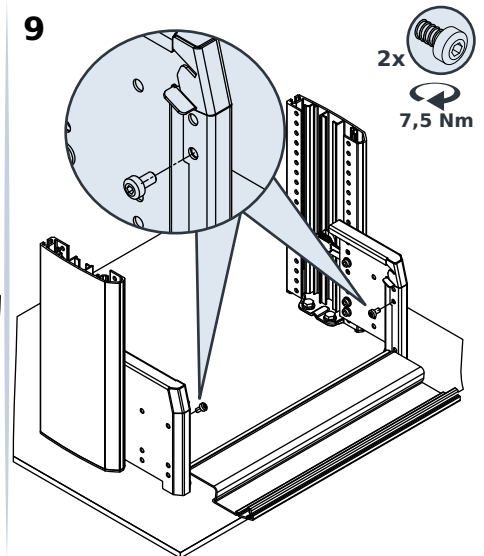

Vloerklep

10

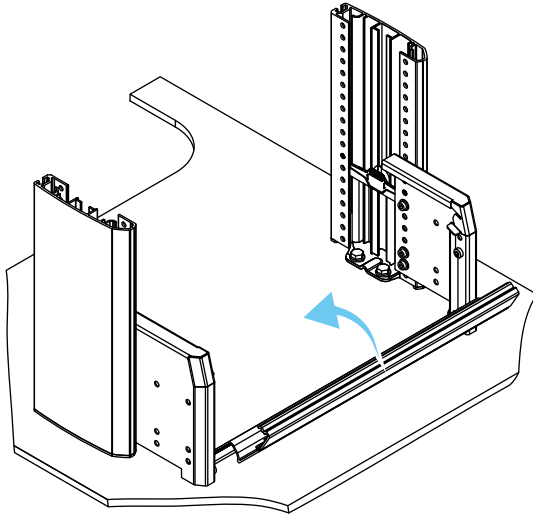

11

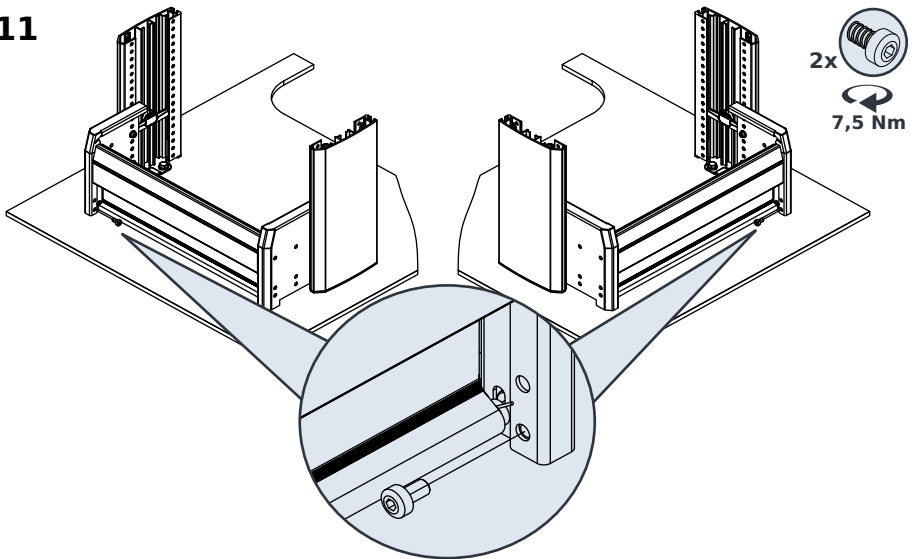

Vloerklep

12

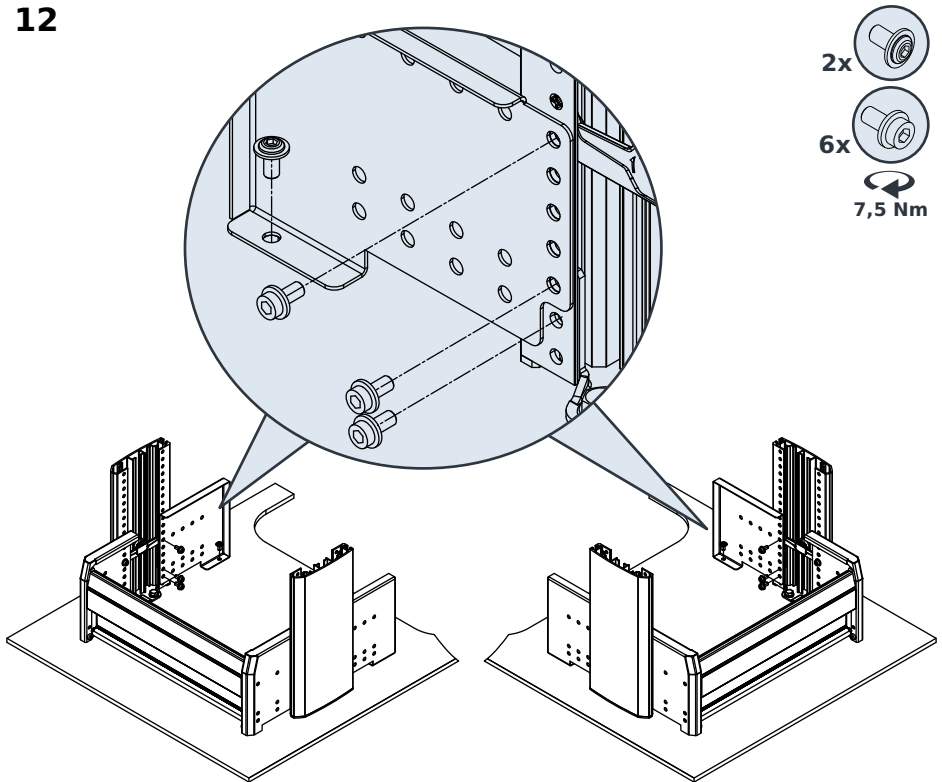

Vloerlep met vastzetrail

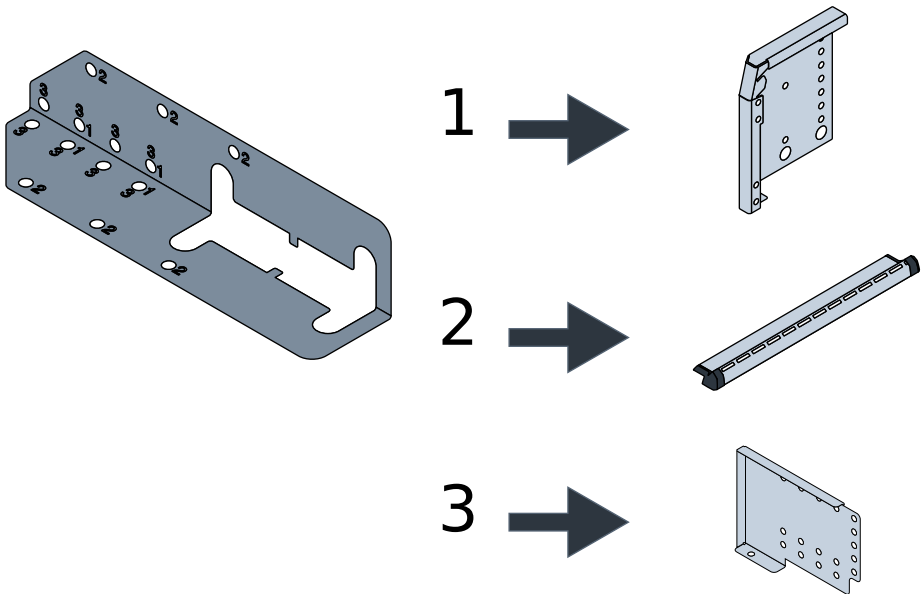
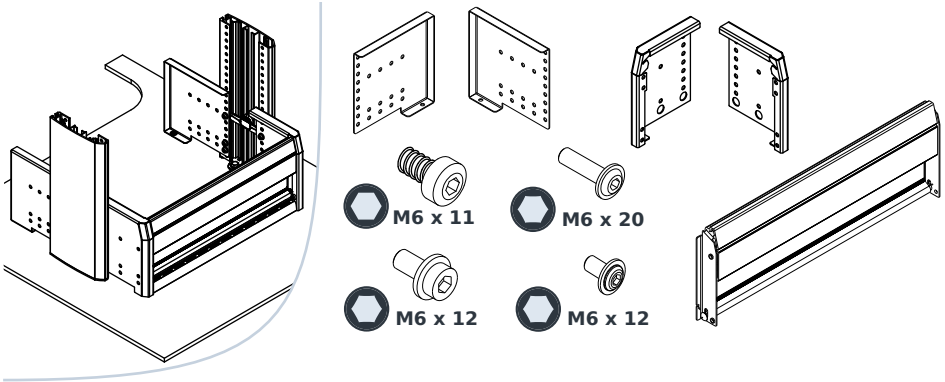

Vloerlepel met vastzetrail

1

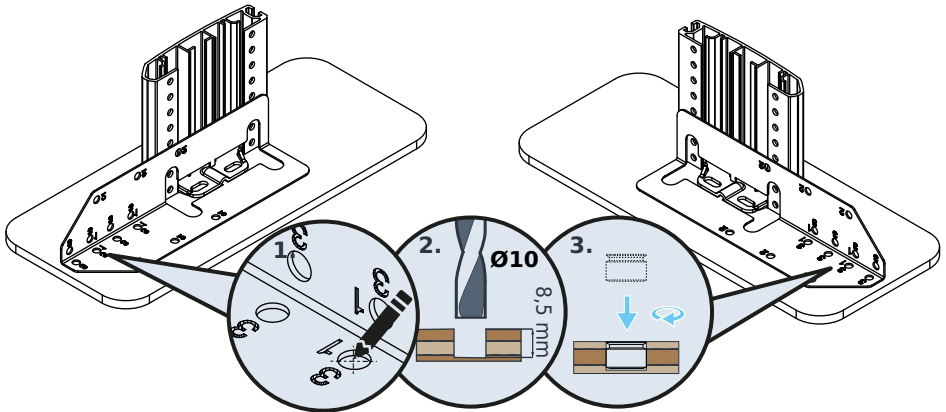

2

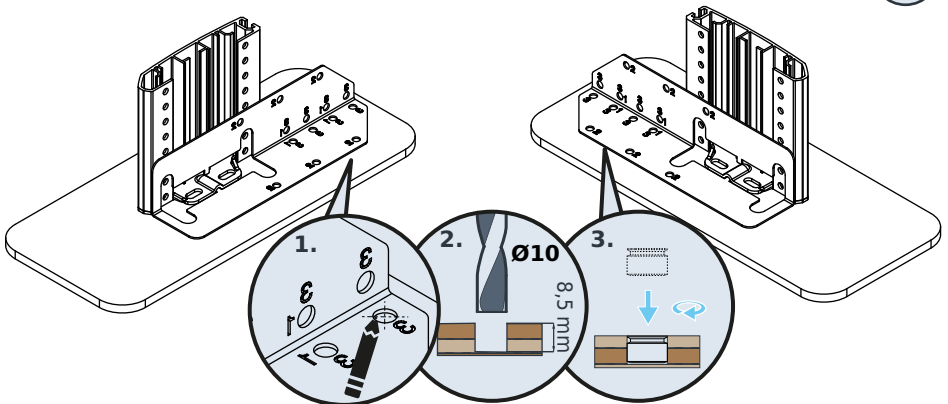

Vloerklep met vastzetrail

3

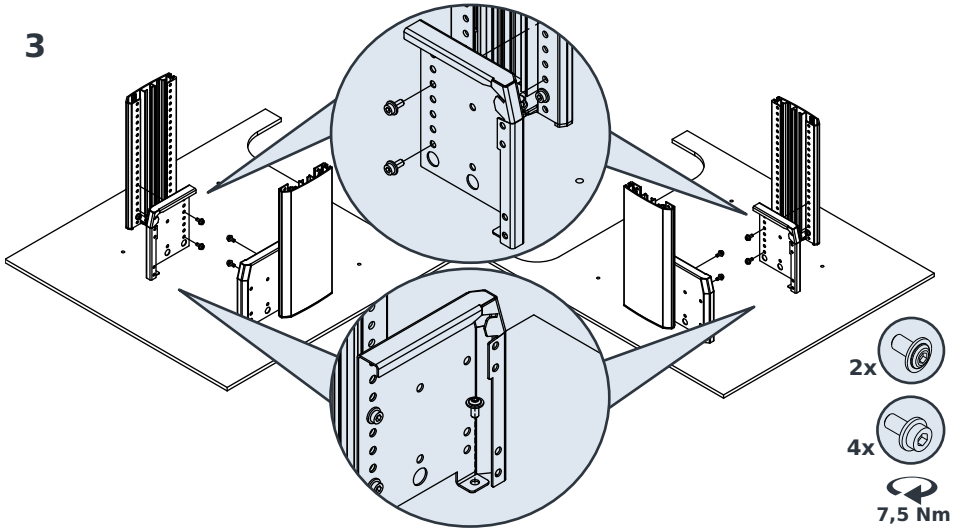

4

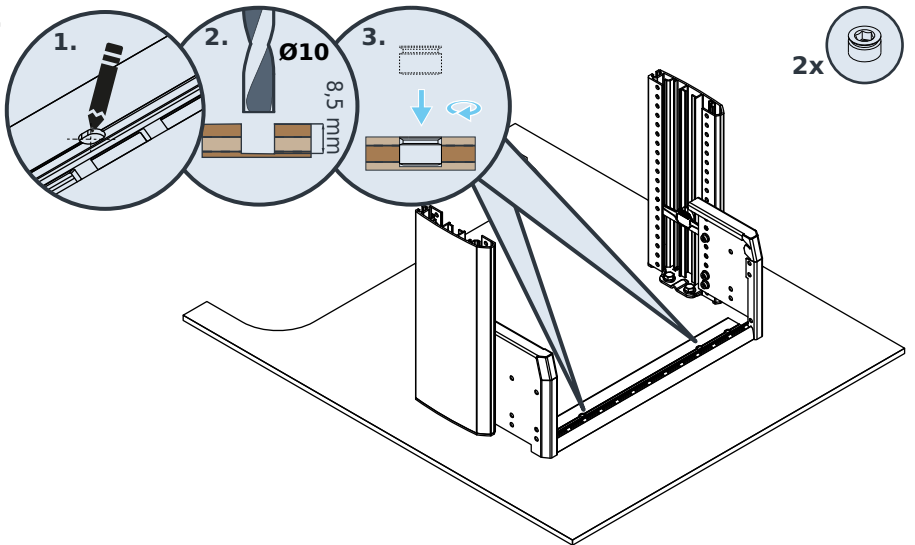

Vloerklep met vastzetrail

20-2



30-2



40-2

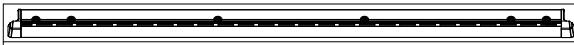

50-2



60-2

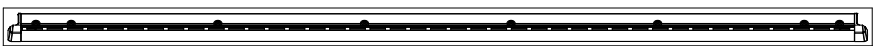

Vloerlep met vastzetrail

7

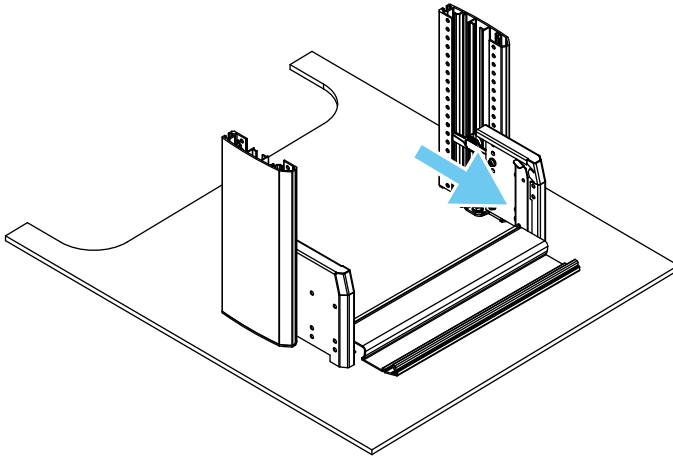

8

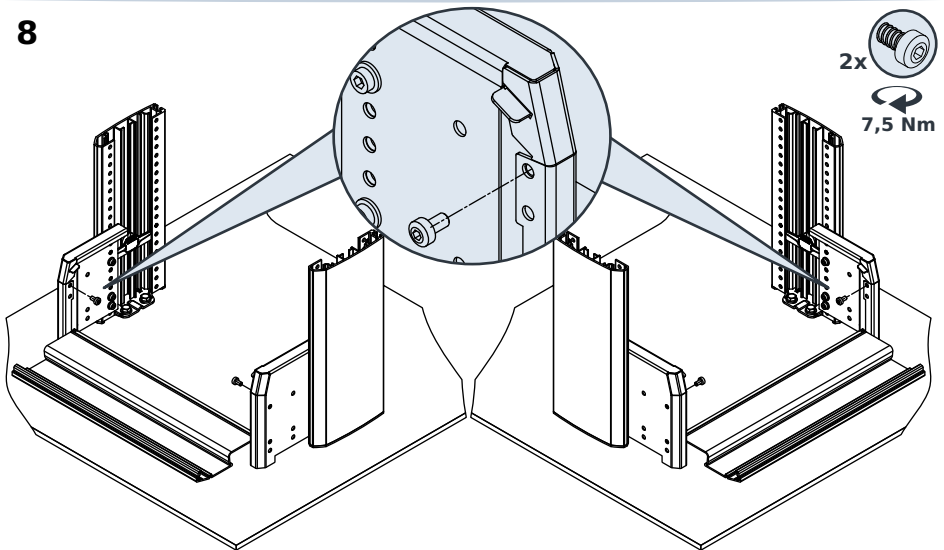

Vloerlep met vastzetrail

9

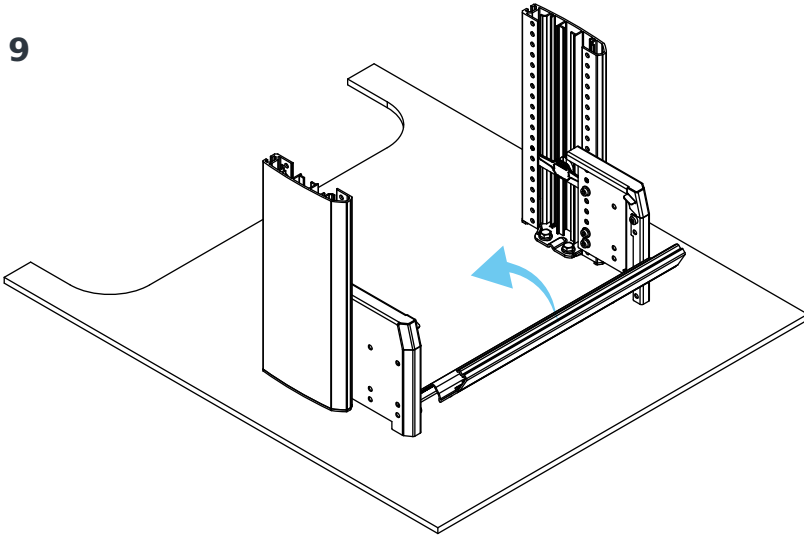

10

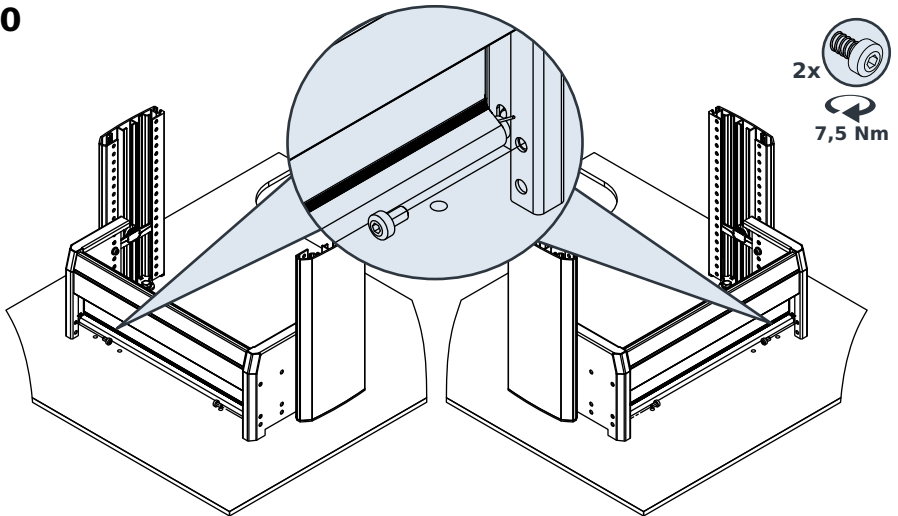

Vloerklep met vastzetrail

11

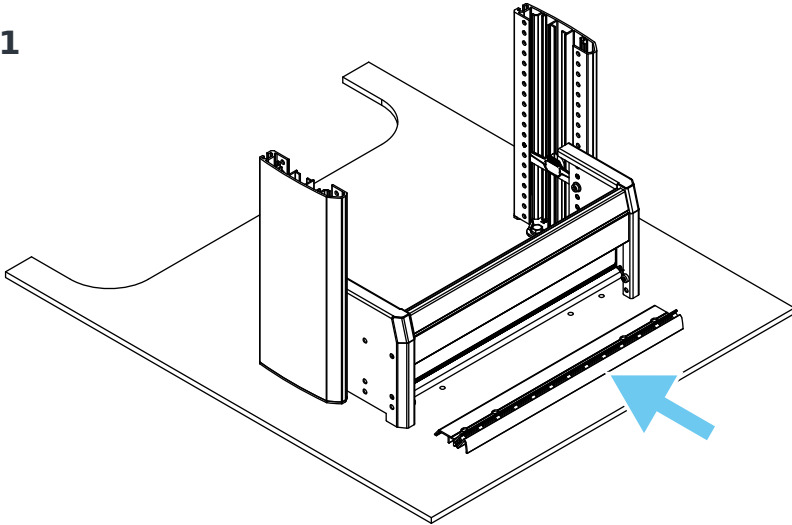

12

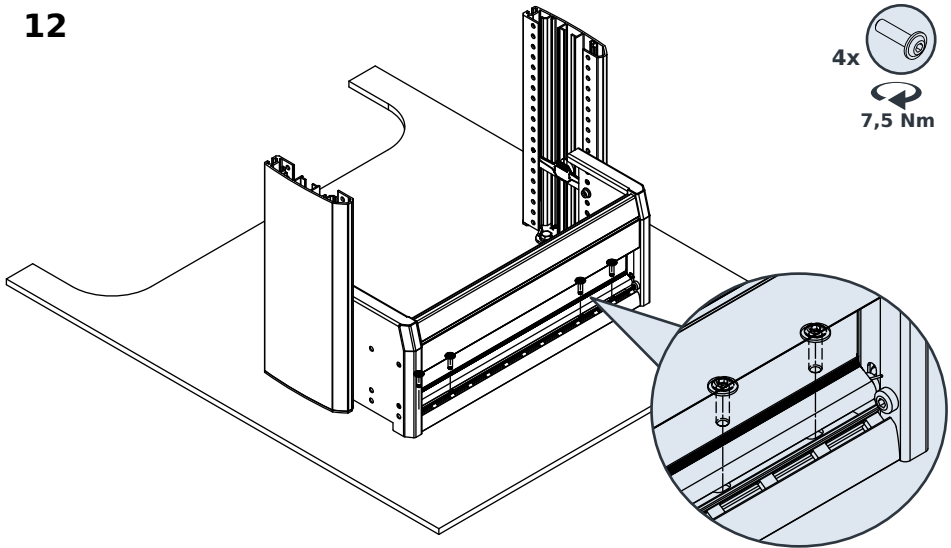

Vloerklep met vastzetrail

13

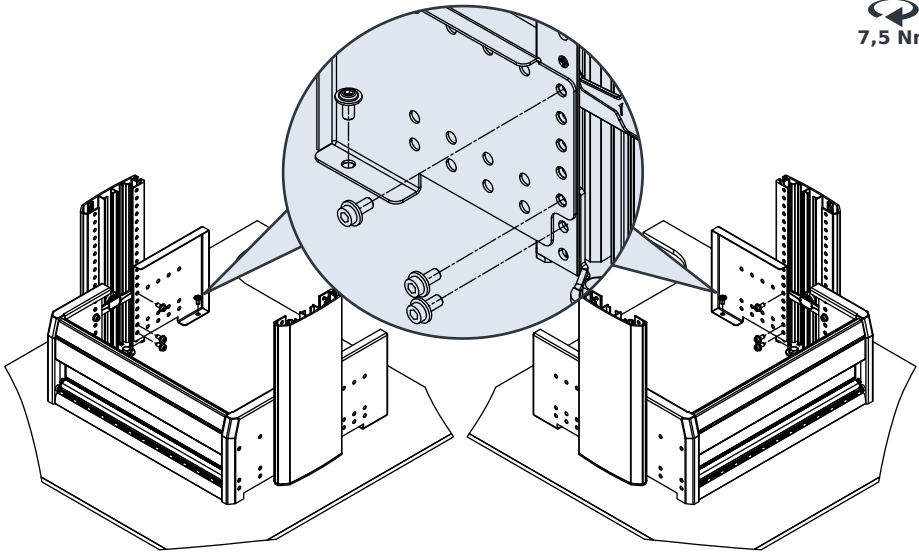
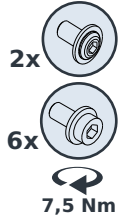

Universeelkast

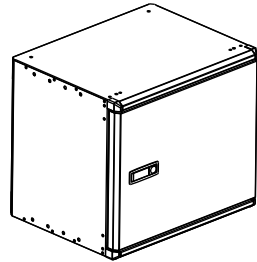
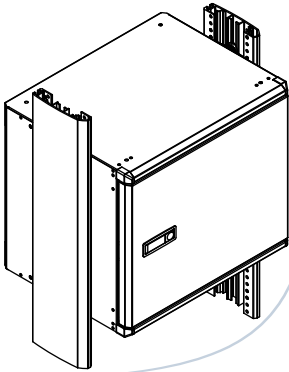

1

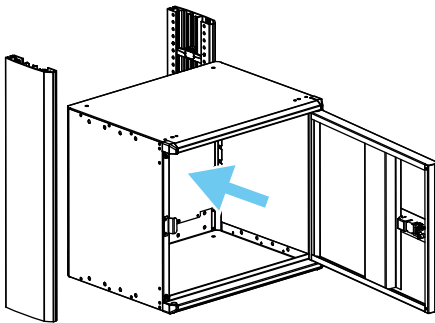

2

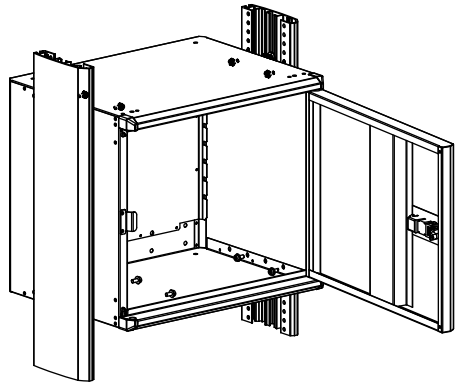

Opklapbare werkbank

Hinweis: Een verbindingsraam of legbord moet worden geplaatst met 3 rasterstussenafstand onder en boven om de stabiliteit van de zijprofielen te garanderen, beginnend vanaf het midden van de bovenverbinding.

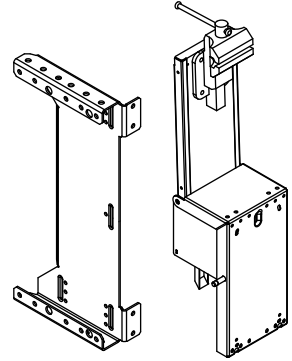
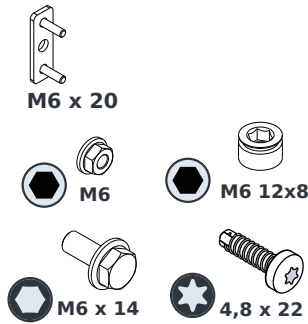
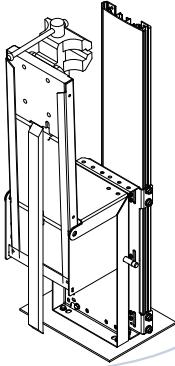

1

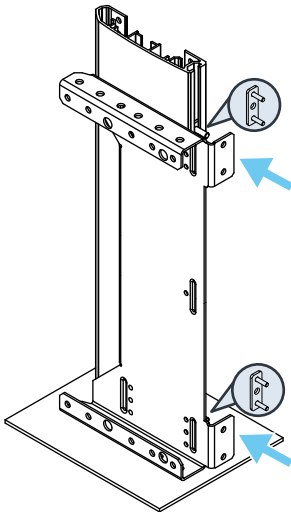

2

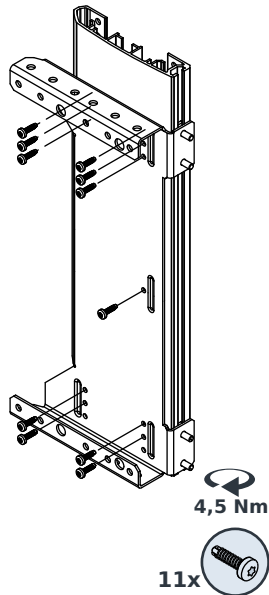

3

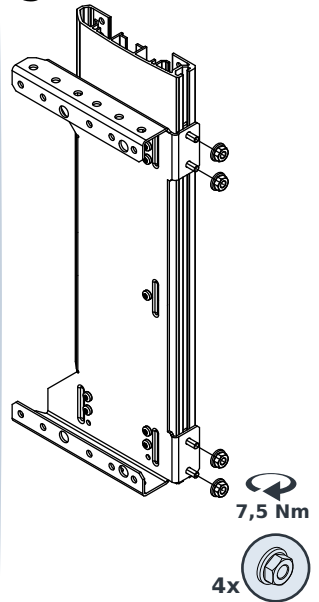

Opklapbare werkbank

min. 0 mm -
max. 63 mm

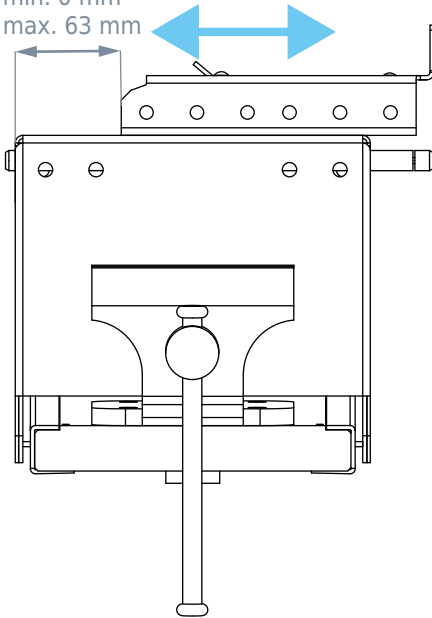

4

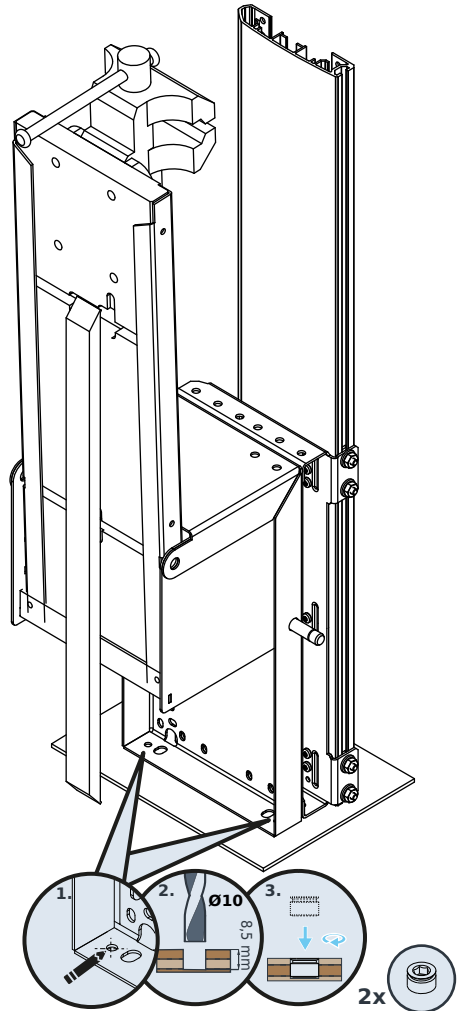

Opklapbare werkbank

5

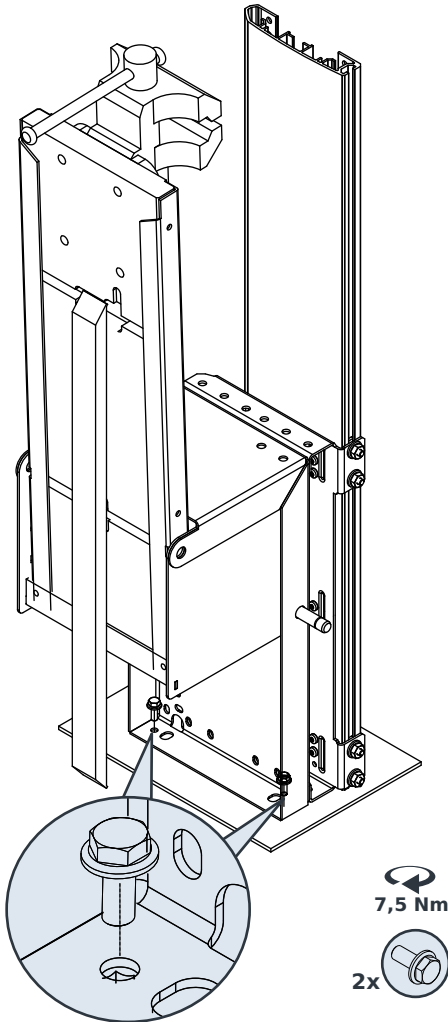

6

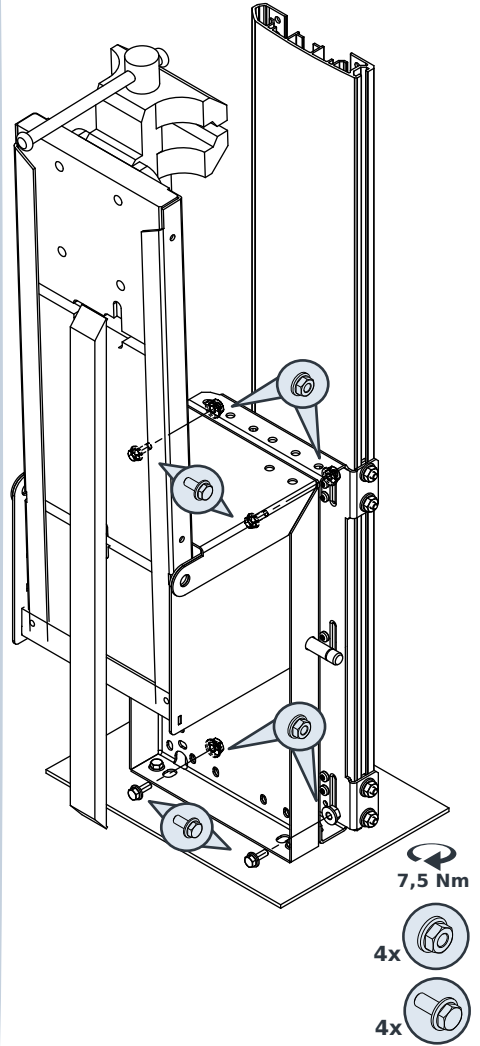

Langmateriaalbak

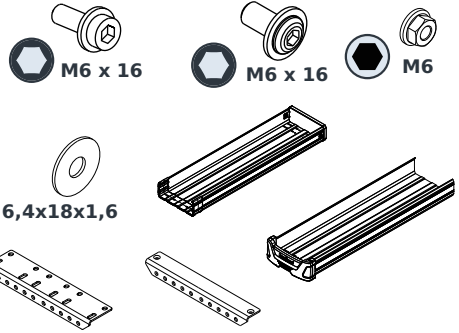
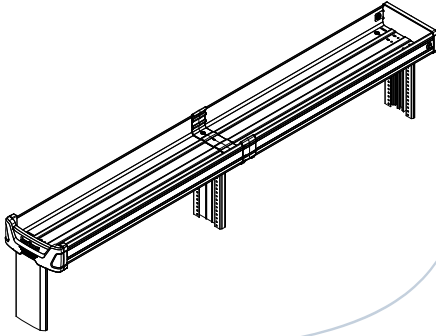

1

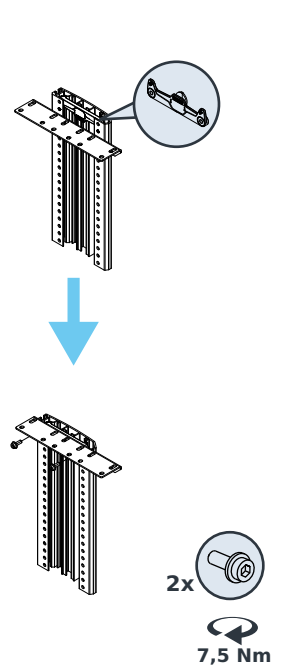
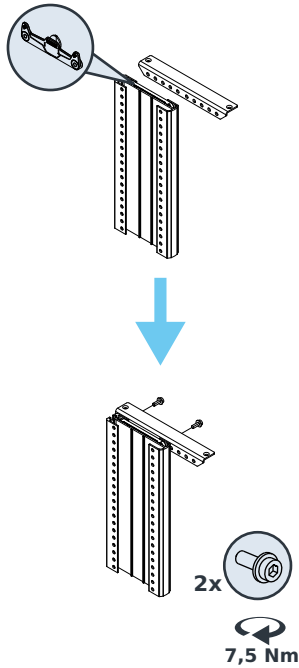
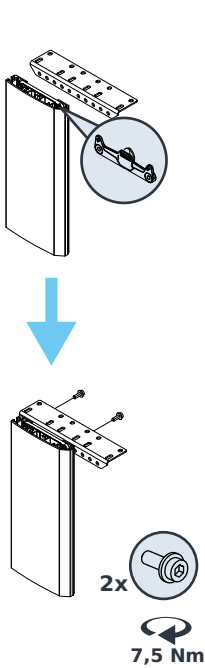

Langmateriaalbak

2

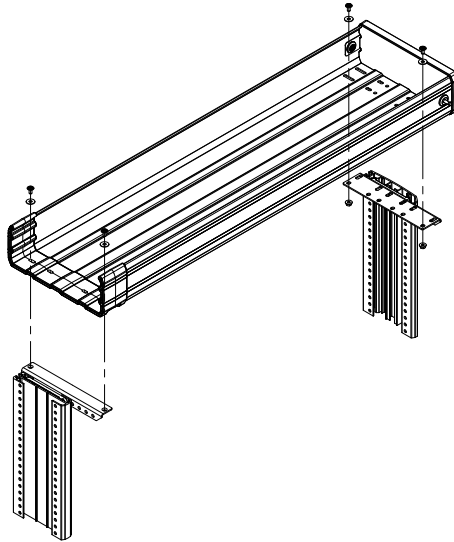

3

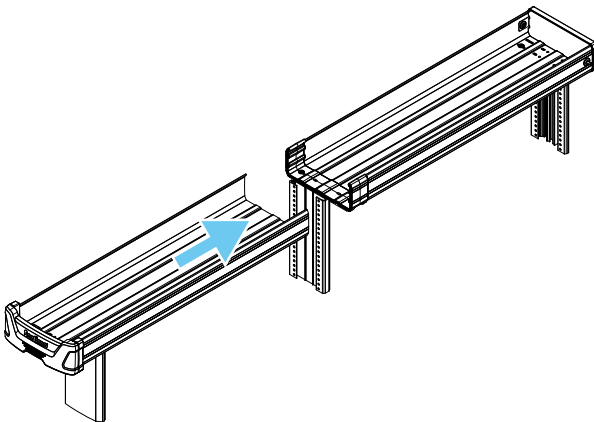

Langmateriaalbak

4

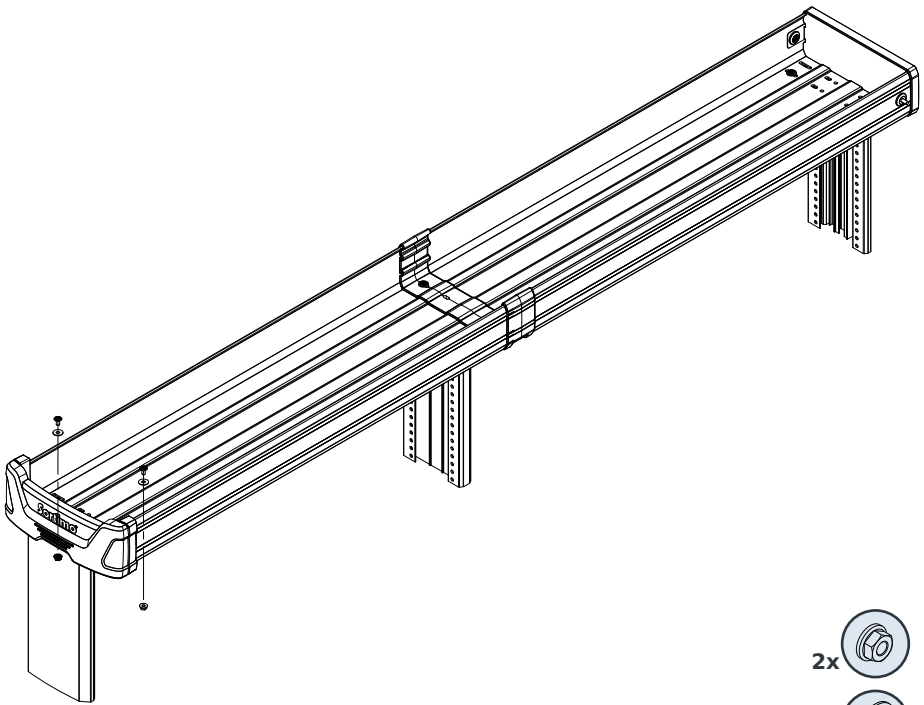

7,5 Nm

Koffergeleider

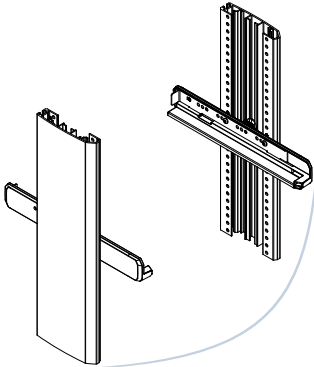

1

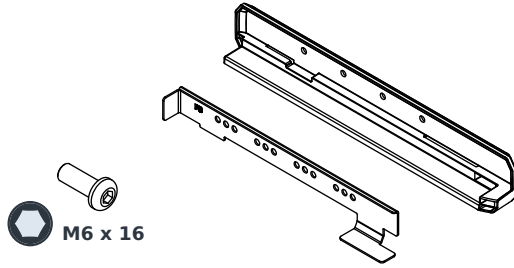

2

3

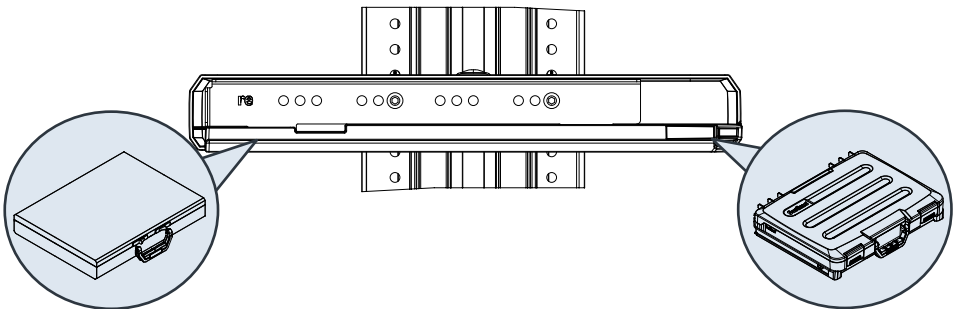
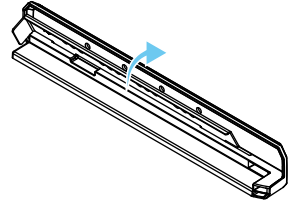
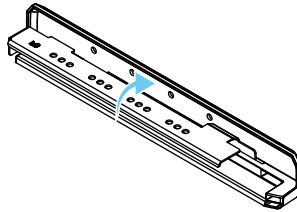
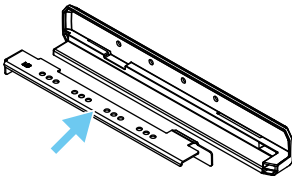

Koffergeleiter

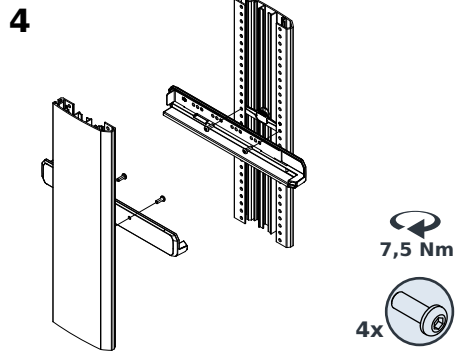
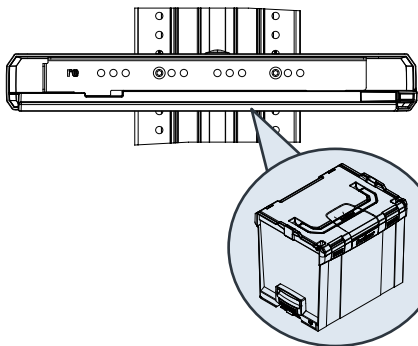
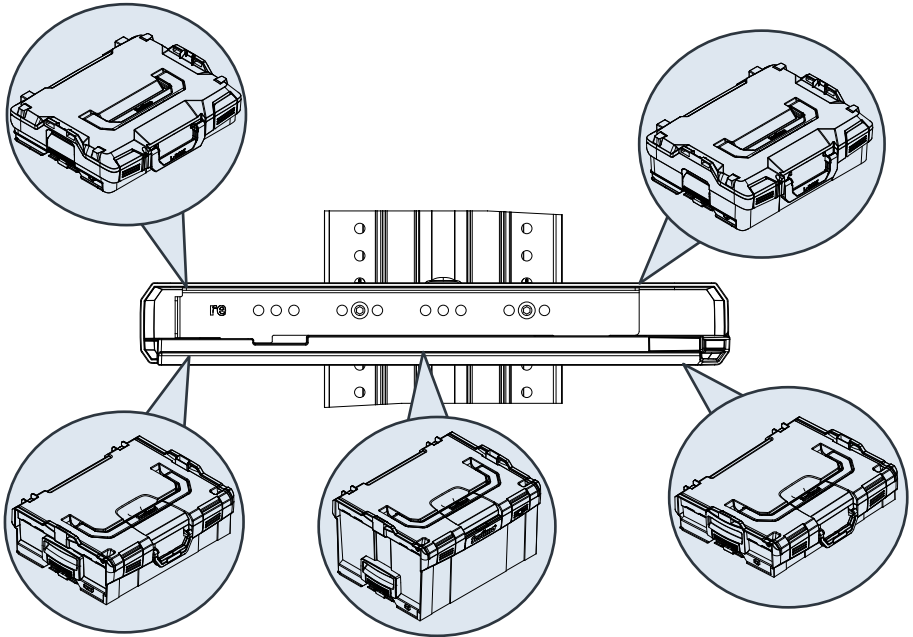

Opklapbare bankschroef

Hinweis: Een verbindingsraam of legbord moet worden geplaatst met 3 raster tussenaafstand onder en boven om de stabiliteit van de zijprofielen te garanderen, beginnend vanaf het midden van de bovenverbinding.

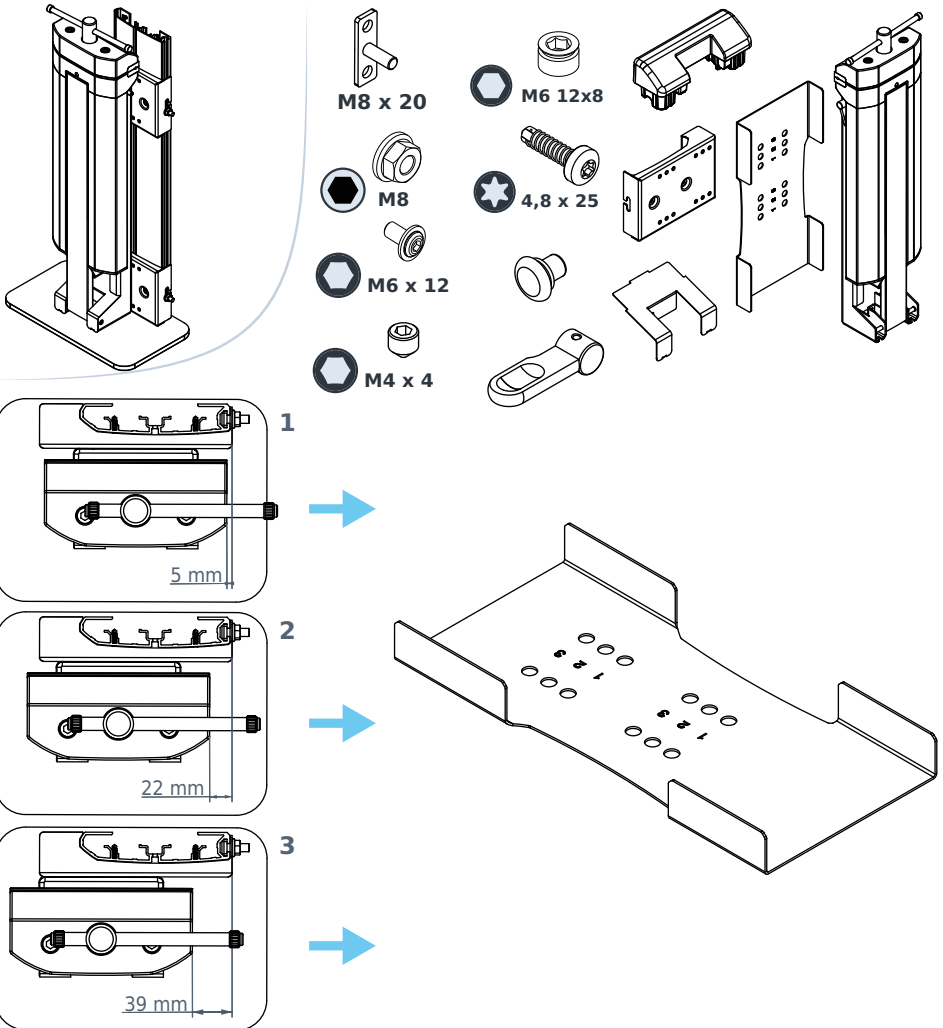

Opklapbare bankschroef

1

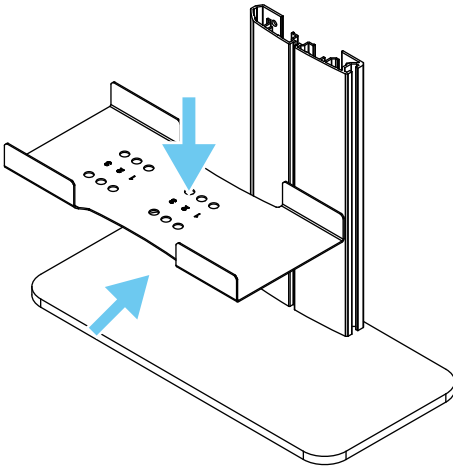

2

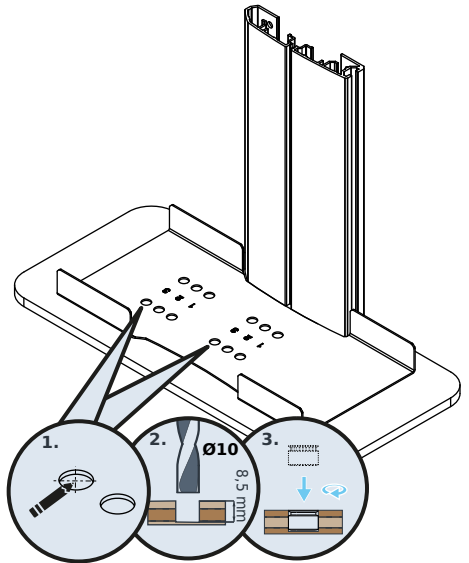

Opklapbare bankschroef

3

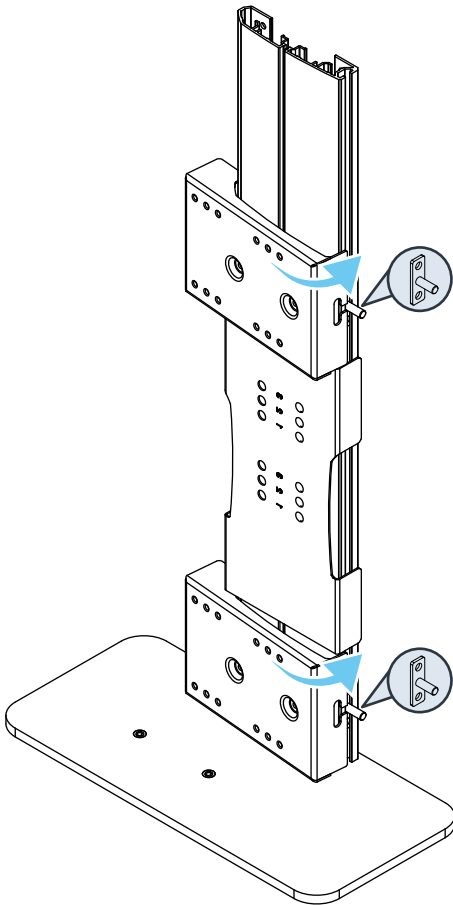

4

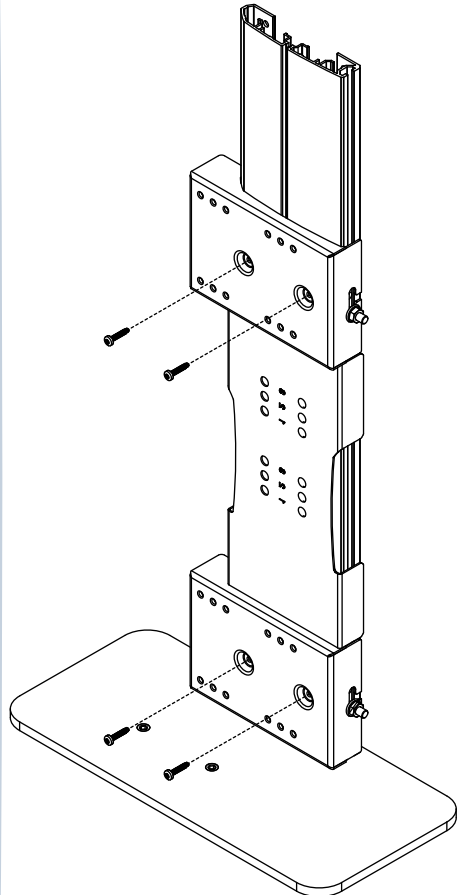

4,5 Nm



Opklapbare bankschroef

5

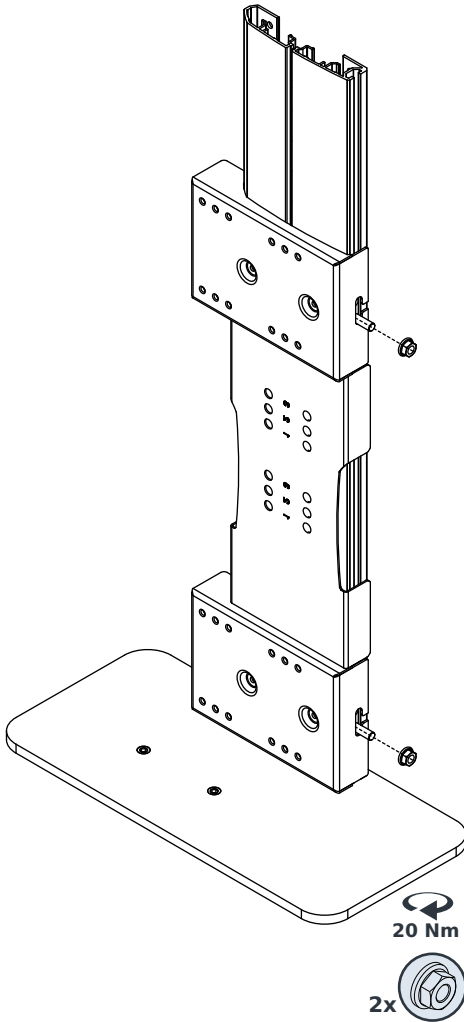

6

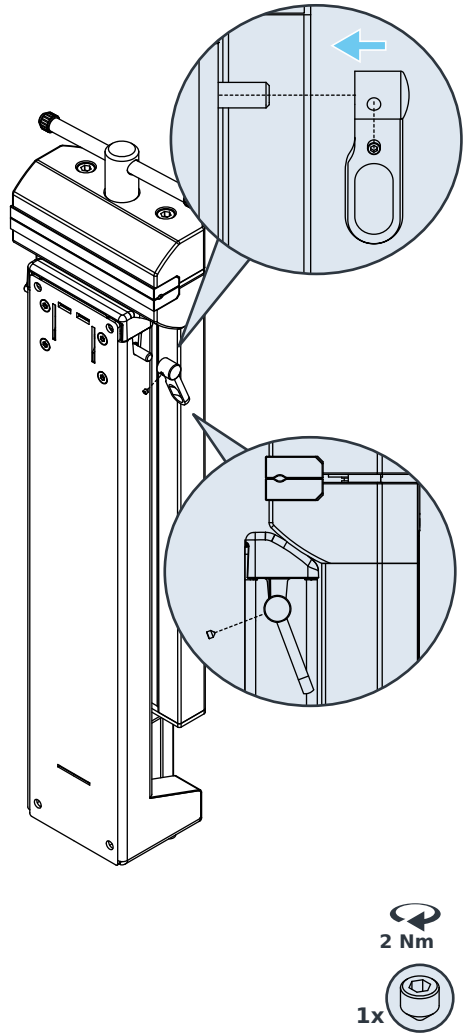

Opklapbare bankschroef

7

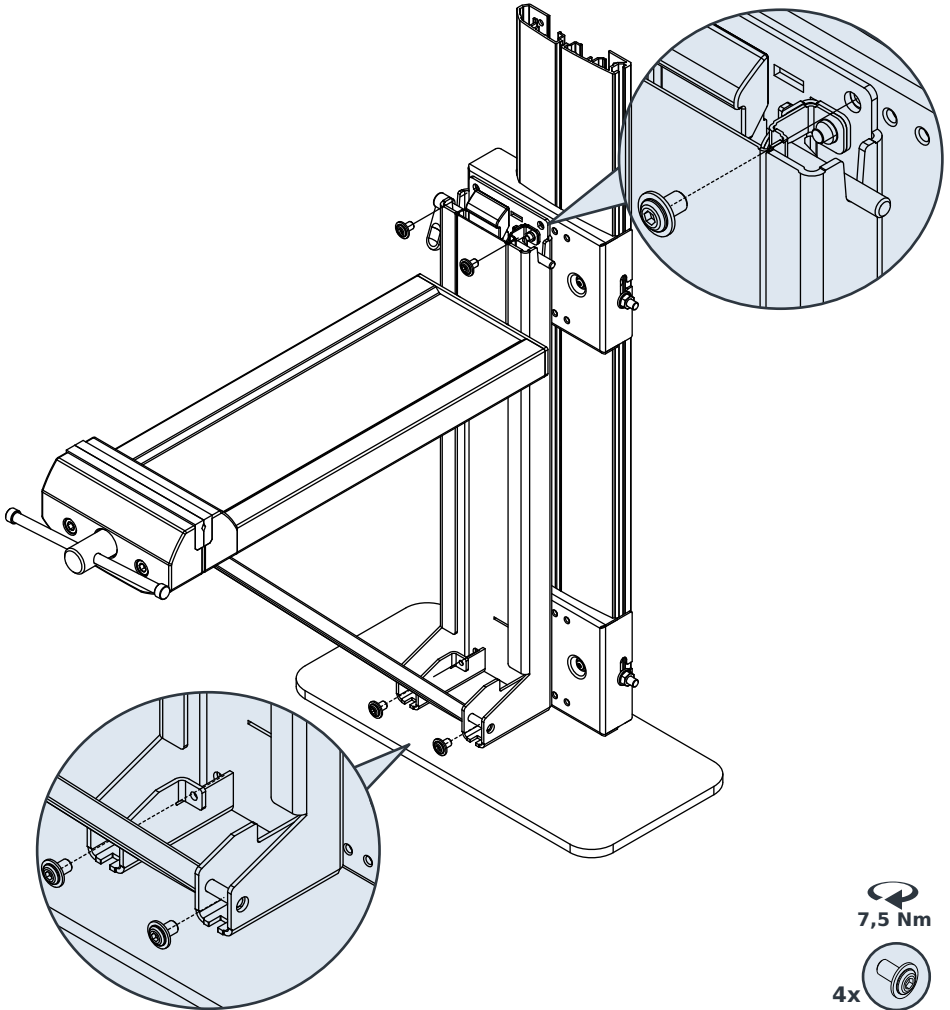

Opklapbare bankschroef

8

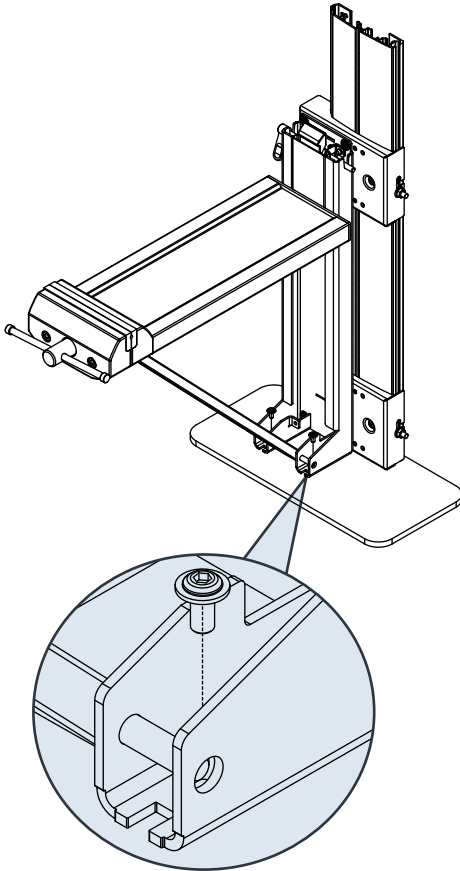

 7,5 Nm

2x 

9

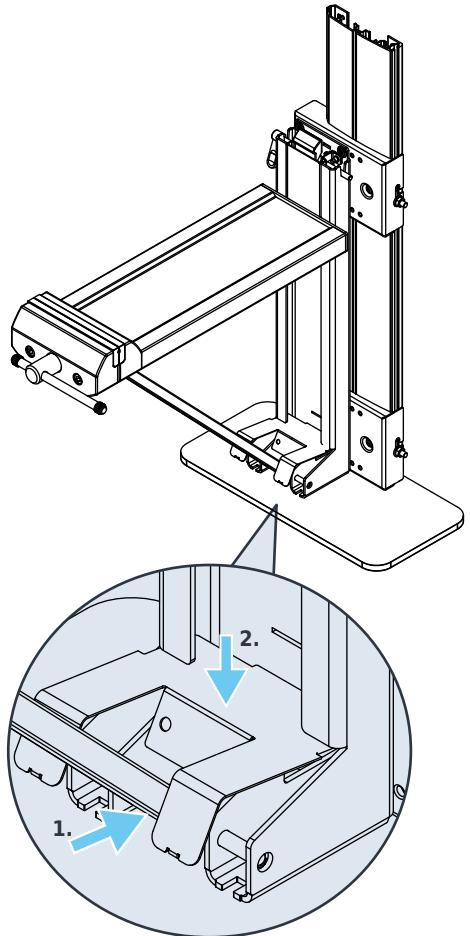

Opklapbare bankschroef

10

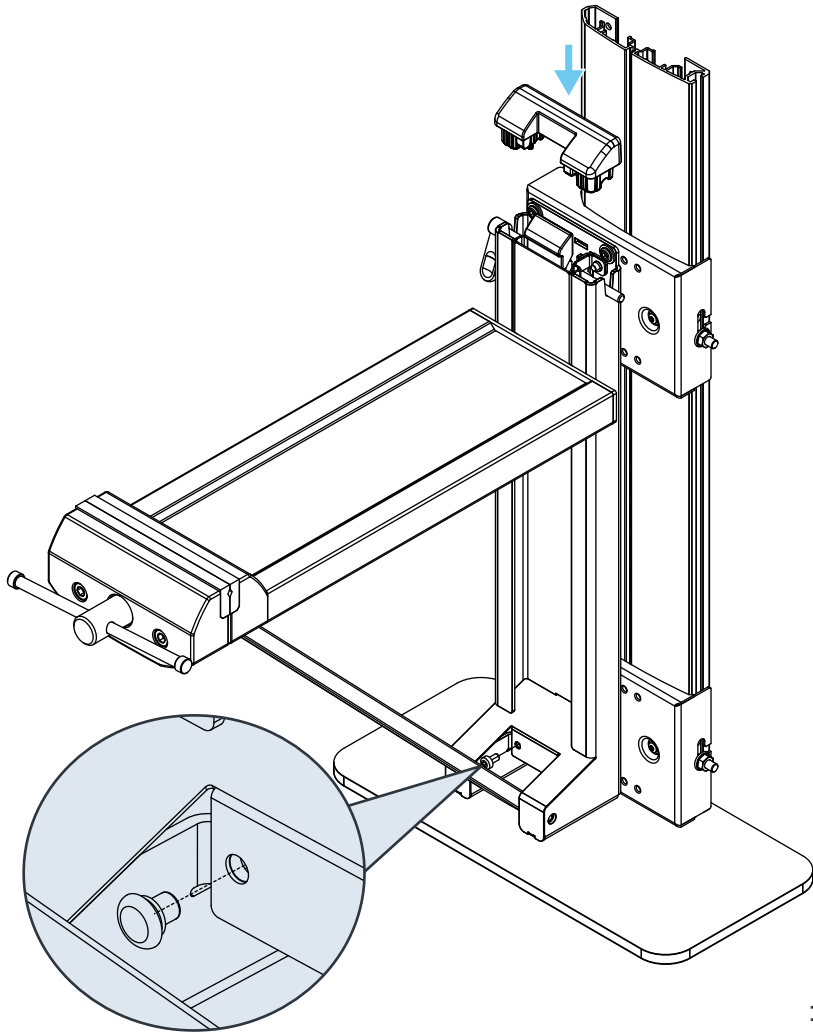

Zijprofiel verticaalverbinder

Hinweis: Per profiel kan maximaal maar één verticaalverbinder worden gemonteerd. Het verlengde profiel mag niet langer zijn dan 500 mm of 30 raster. Er is een extra muurbevestiging nodig voor onderdelen die boven de verticaalverbinder zijn aangebracht.

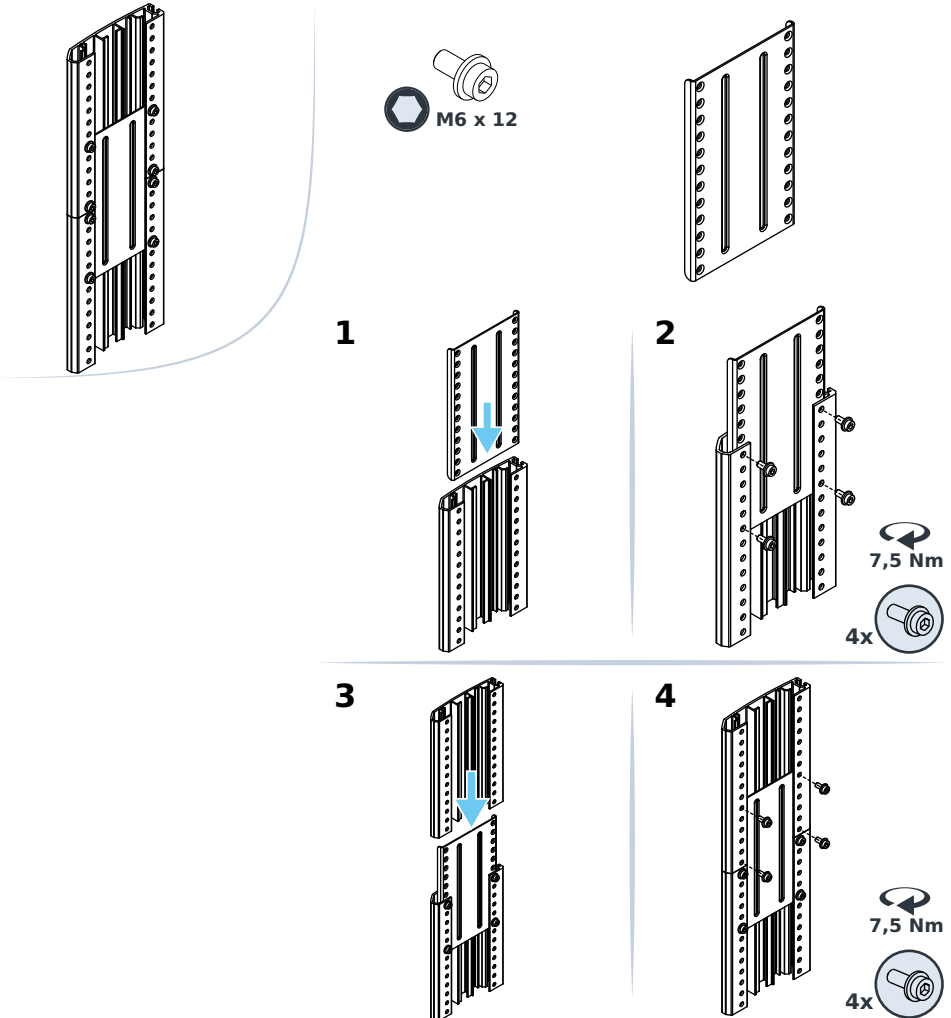

Tussenprofiel verticaalverbinder

Hinweis: Per profiel kan maximaal maar één verticaalverbinder worden gemonteerd. Het verlengde profiel mag niet langer zijn dan 500 mm of 30 raster. Er is een extra muurbevestiging nodig voor onderdelen die boven de verticaalverbinder zijn aangebracht.

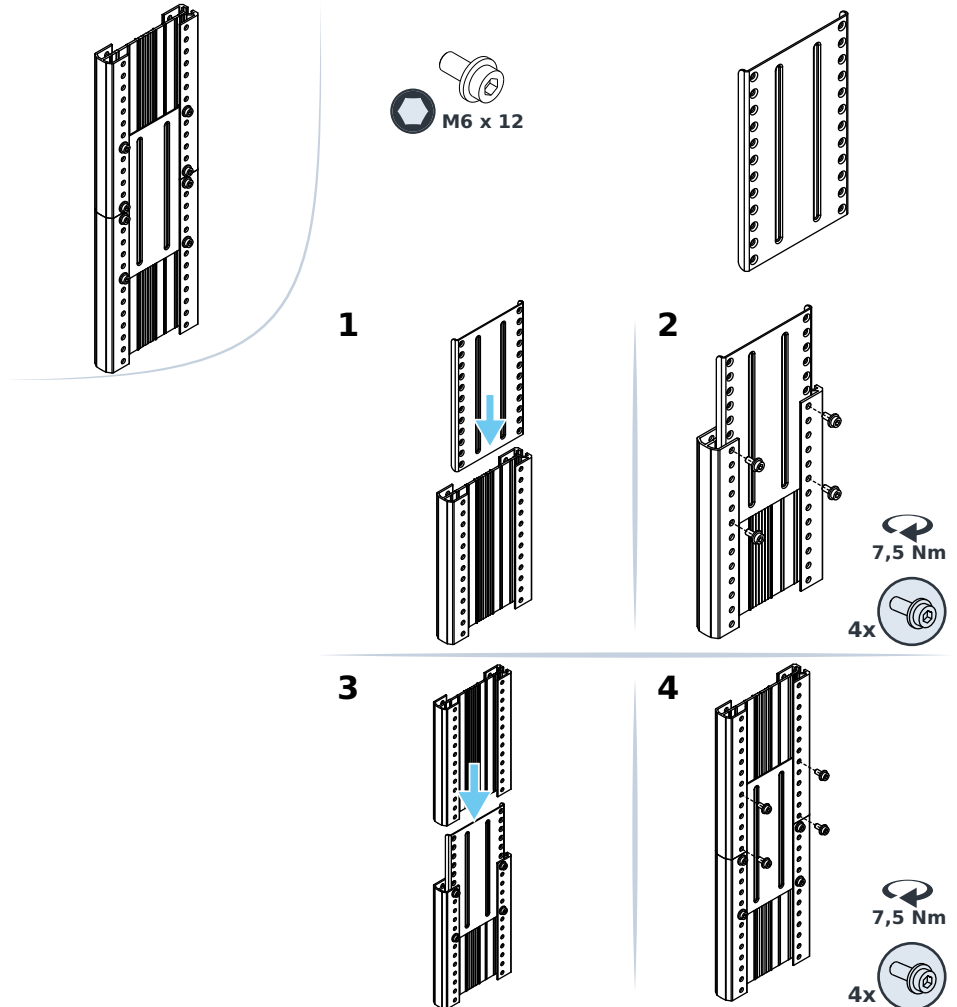

BOXXen ramen

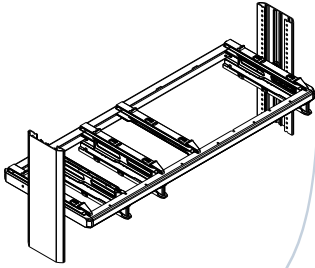

1

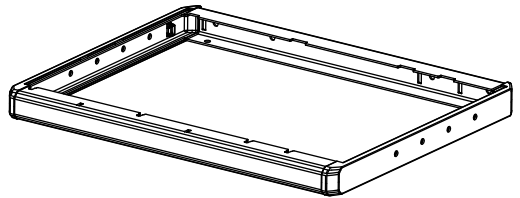

2

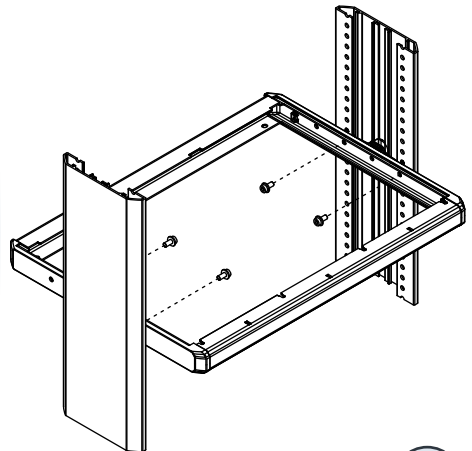
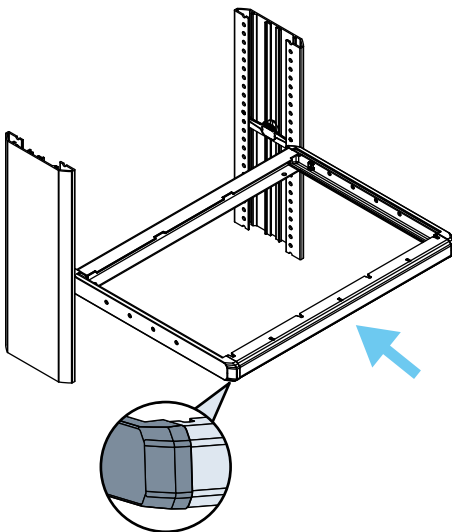

Werkblad op raam

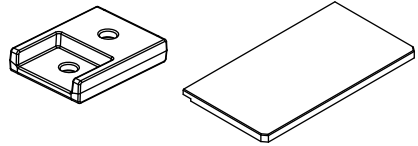
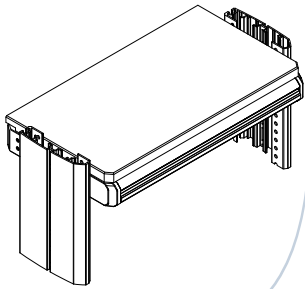

1

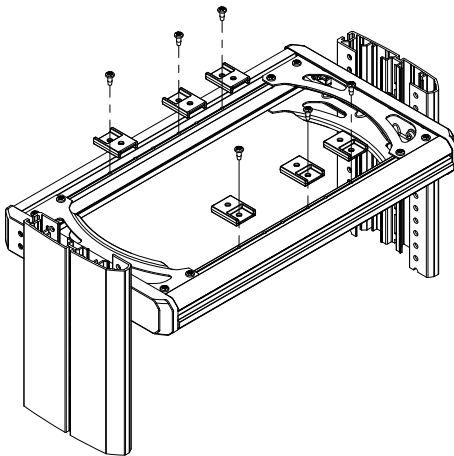

2

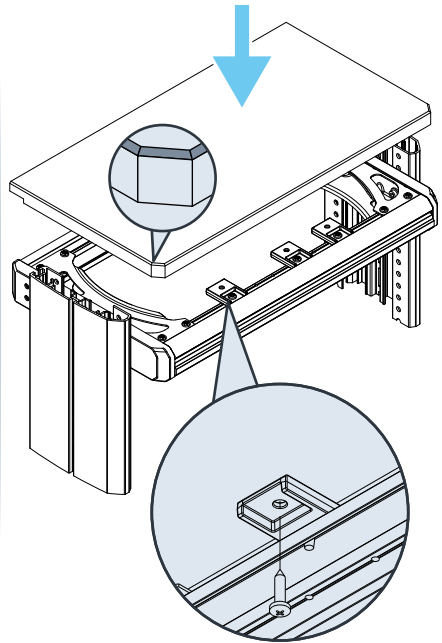

Draaiblok 90° T4/T5



WAARSCHUWING

Letselgevaar door ontbrekende voertuigcomponenten

Lading kan uit het reksysteem in de inzittendenruimte terechtkomen. Ernstig tot dodelijk letsel kan het gevolg zijn.

- ▶ Toegestane montage.
 - ▷ Getest verdeelschot conform DIN ISO 27956,
 - ▷ Verdeelschot met schuifdeur.
- ▶ Als u vragen hebt, neem dan contact op met de Technische support van de fabrikant.
- ▶ **Niet** toegestane montage.
 - ▷ Met scheidingsrooster
 - ▷ Zonder verdeelschot

Opmerking: Afhankelijk van de configuratie zijn bepaalde elementen niet opgenomen.

Leveringsomvang

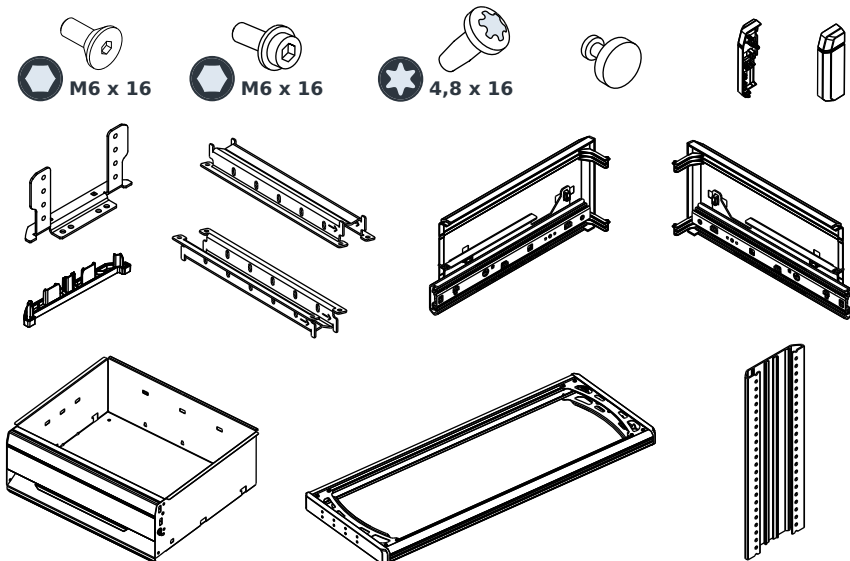

Stap 1 — Basisframe monteren

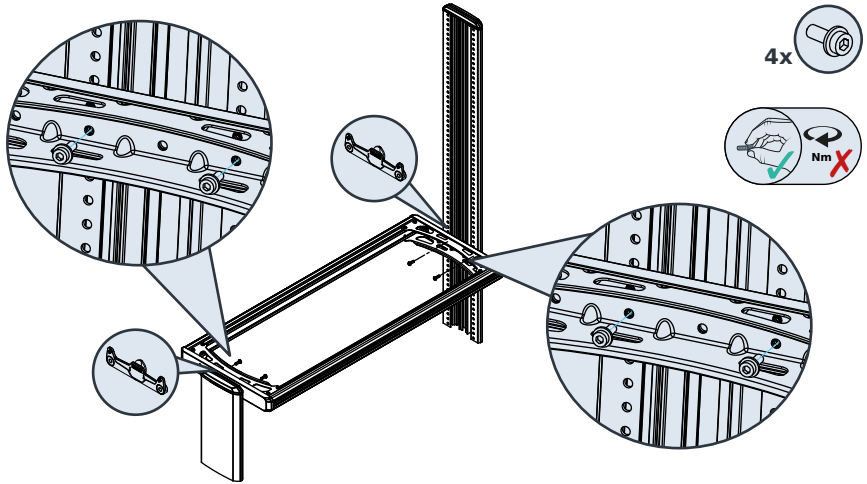

Stap 2 — Draiblokprofielen monteren

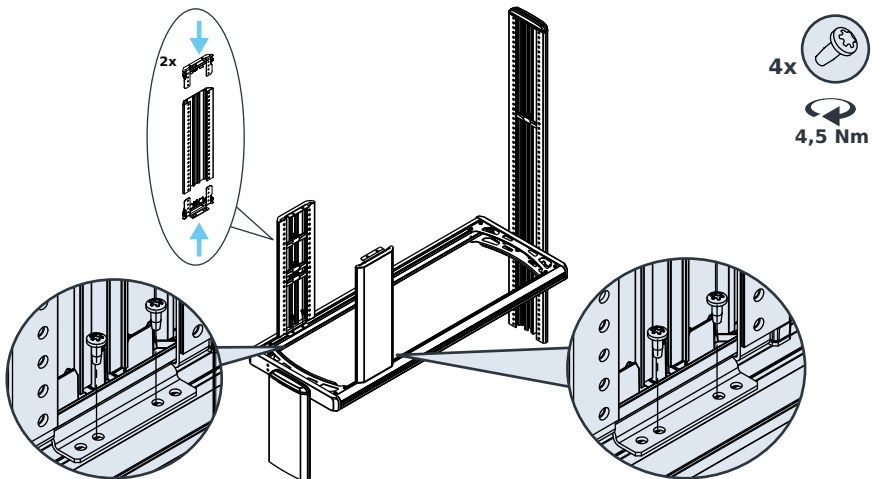

Stap 3 — Afsluitingsframe monteren

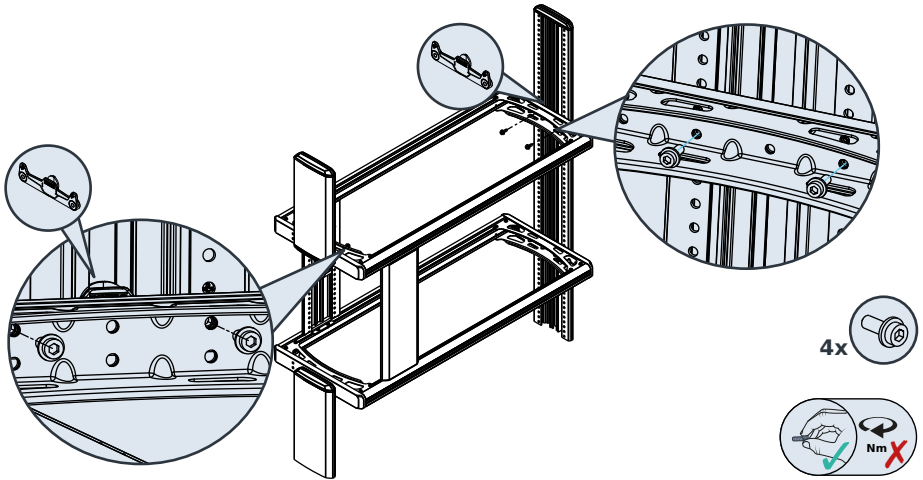

Stap 4 — Tussenprofiel voorbereiden

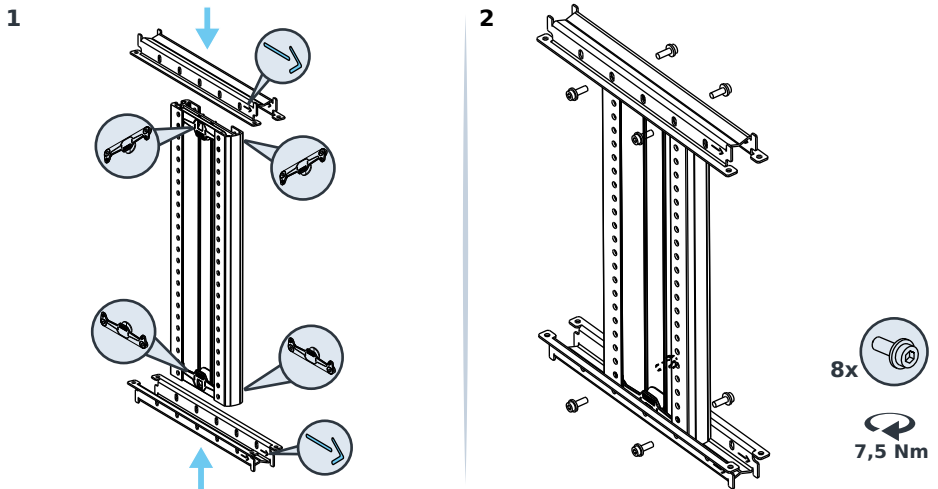

Stap 5 — Tussenprofiel monteren

1

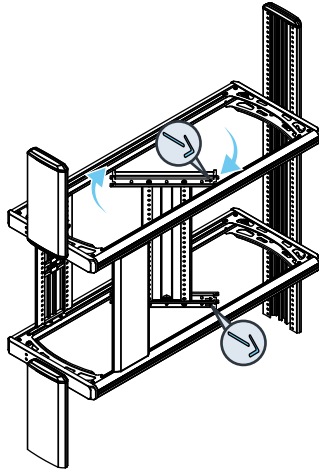

2

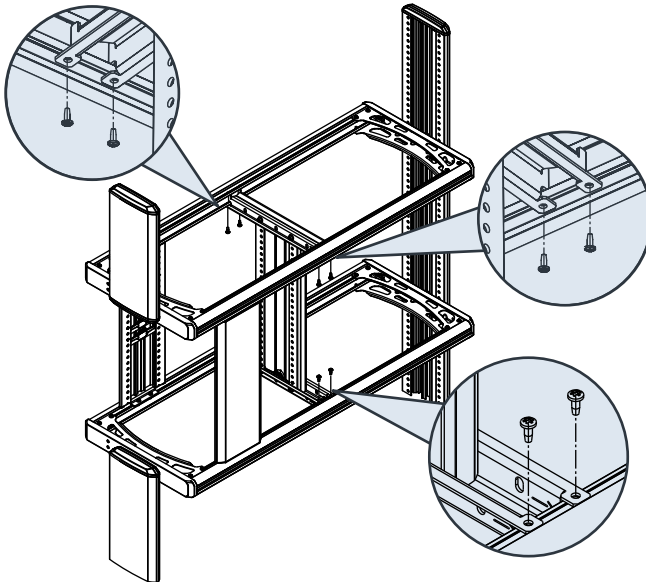

Stap 6 — Schuifladen monteren

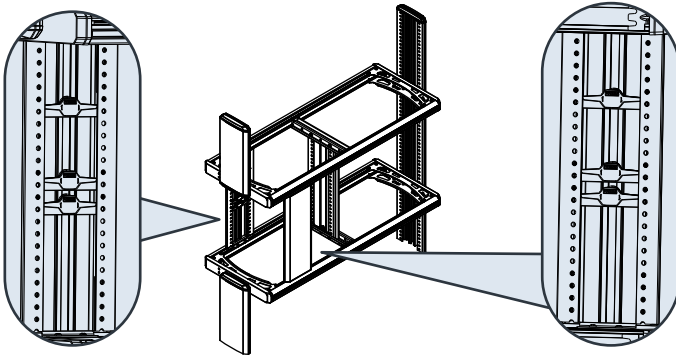

1

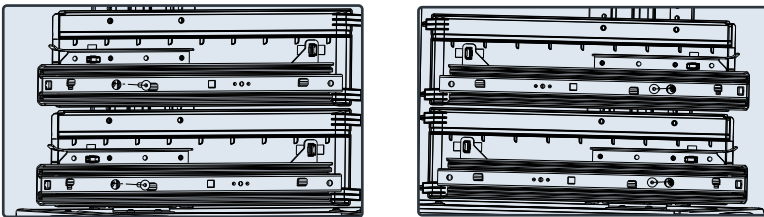

2

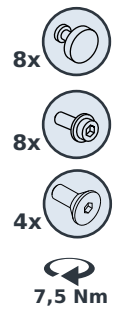
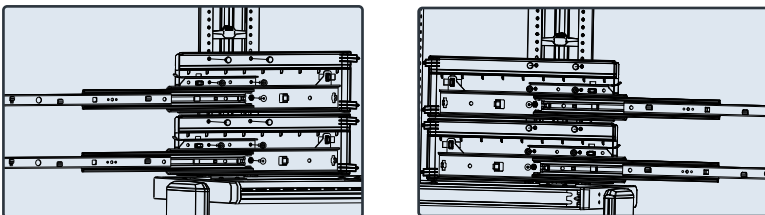

Stap 6 – Schuifladen monteren

3

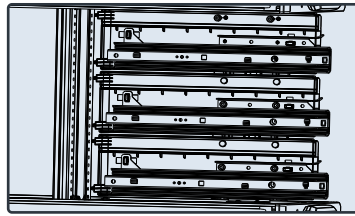
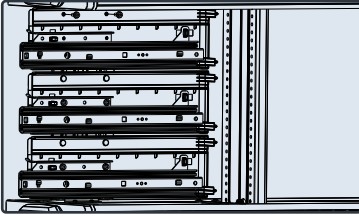

4

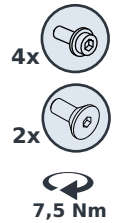
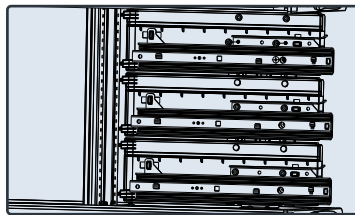
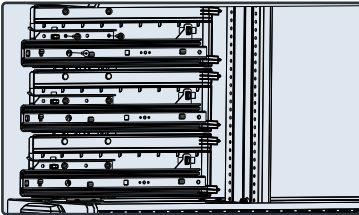

5

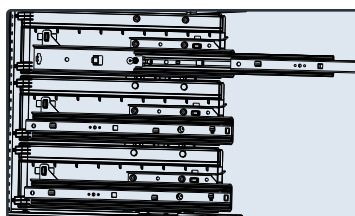
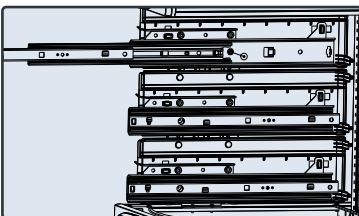

Stap 6 – Schuifladen monteren

6

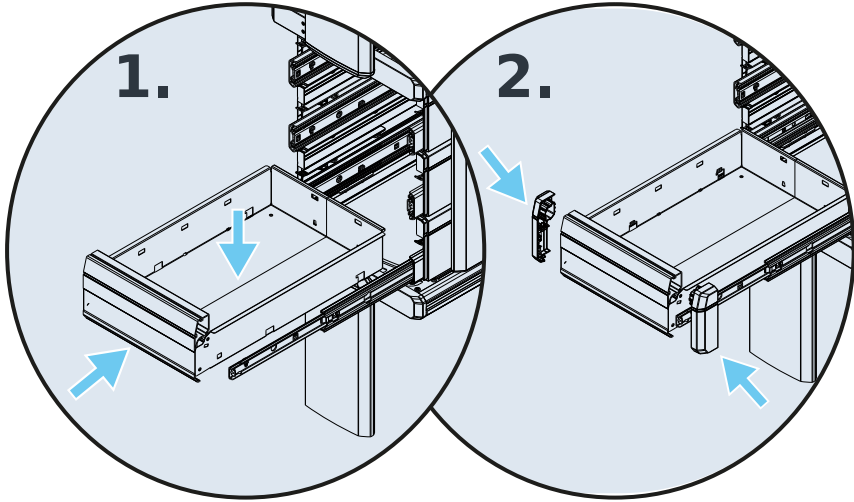

7

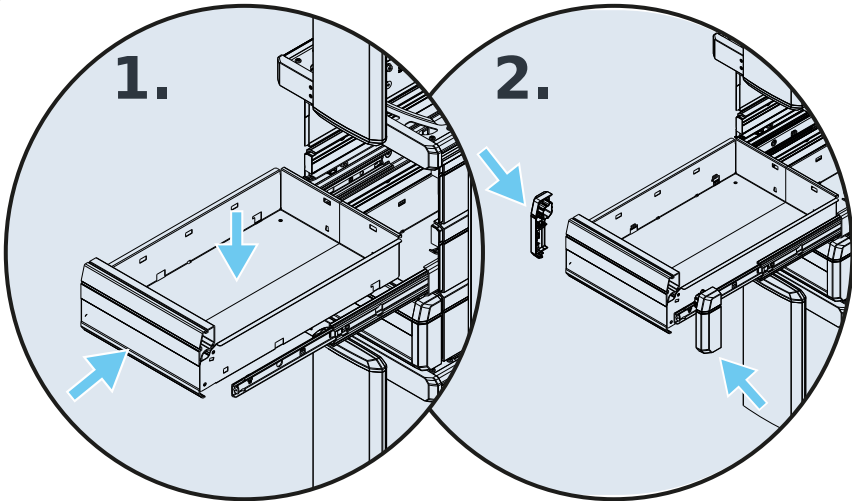

Stap 6 – Schuifladen monteren

8

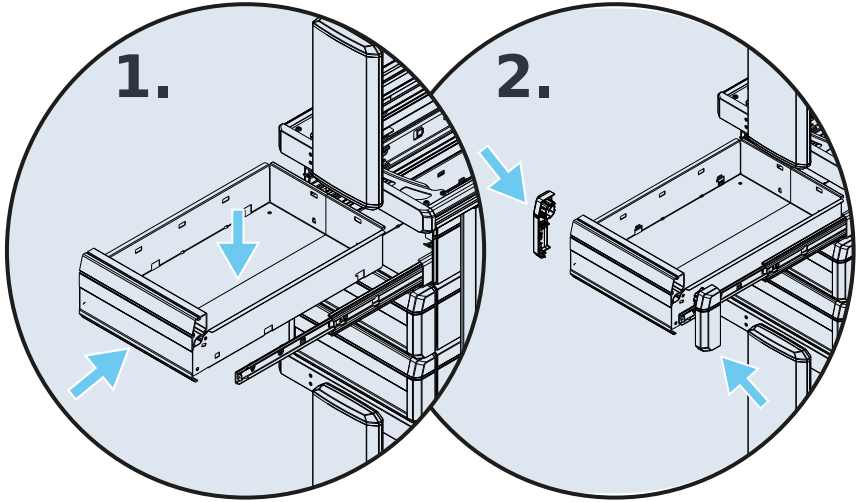

9

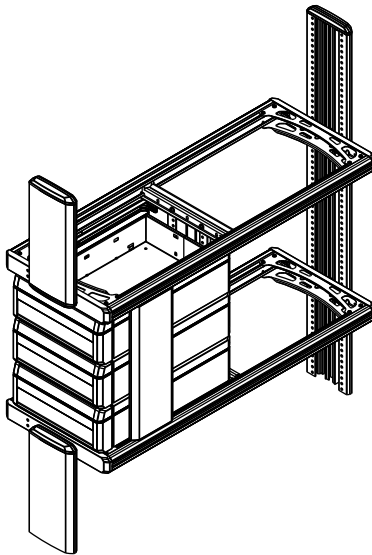

90° T7 twee richtingen blok



WAARSCHUWING:

Gevaar voor letsel door missende componenten

Lading uit de inrichting, kan in de bestuursruimte komen. Dit kan resulteren in zwaar of fataal letsel.

- ▶ Geautoriseerde installatie
 - ▷ Gecertificeerde tussenwand volgens DIN ISO 27956
 - ▷ Tussenwand met schuifdeur
- ▶ Als u vragen heeft, neemt u dan contact op met de technische klantenservice van de fabrikant.
- ▶ Geautoriseerde installatie
 - ▷ Met tussenwand rooster
 - ▷ Zonder ProPartition

Opmerking: Bepaalde onderdelen zijn niet inbegrepen, afhankelijk van de configuratie

Omvang van de levering

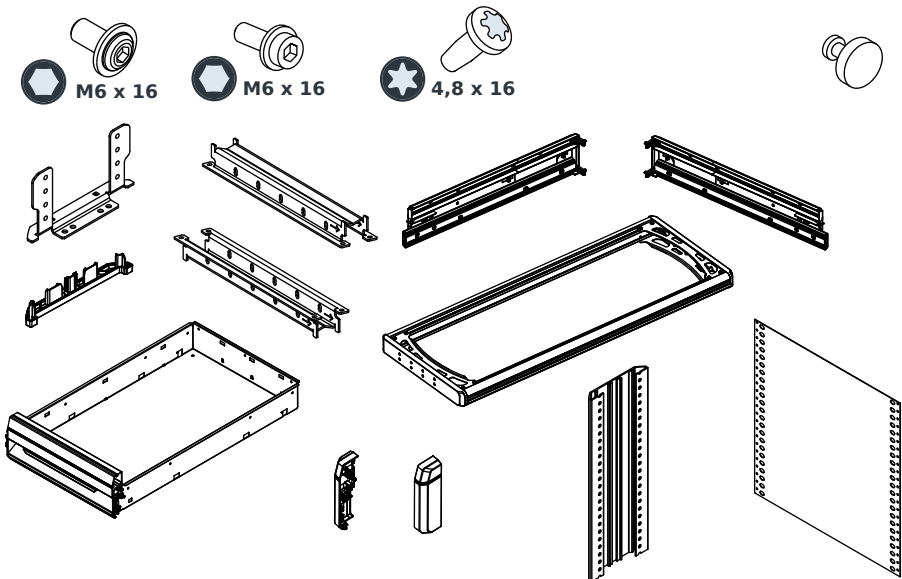

Stap 1 — Installatie van het basis frame

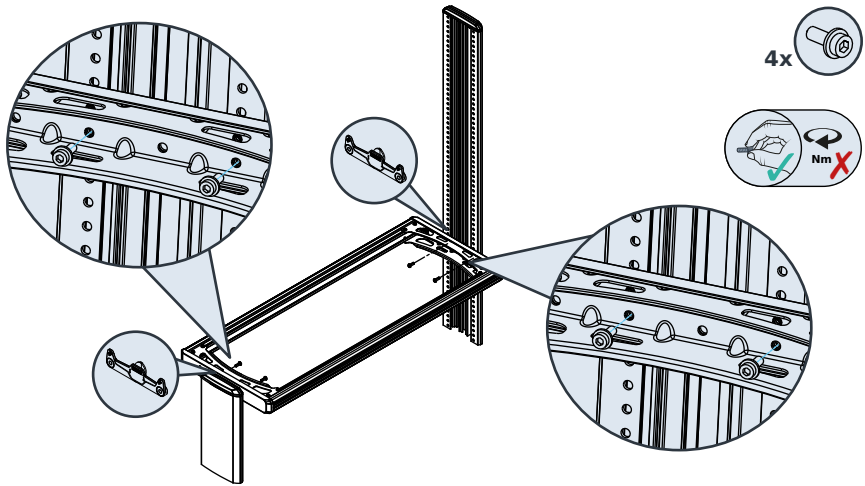

Stap 2 — Installatie van twee richtingen blokprofielen

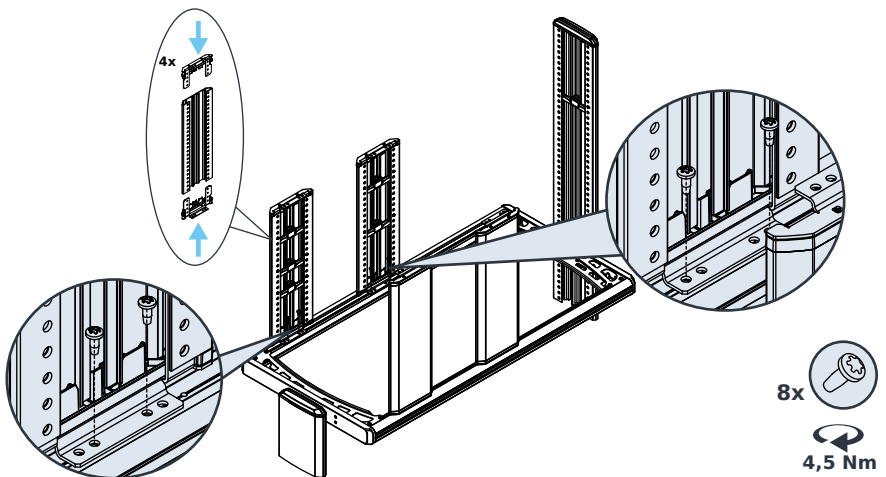

Stap 3 — Installatie van boven frame

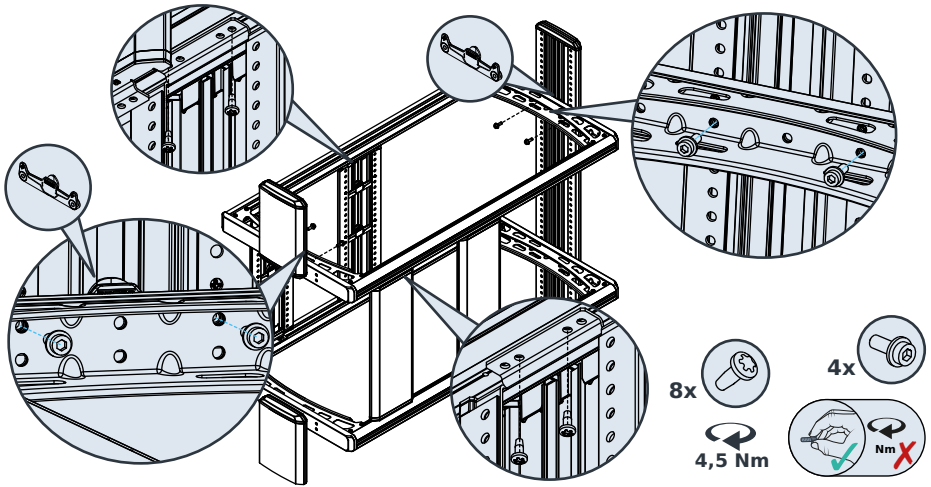

Stap 4 — Voorbereiding van de tussenprofielen

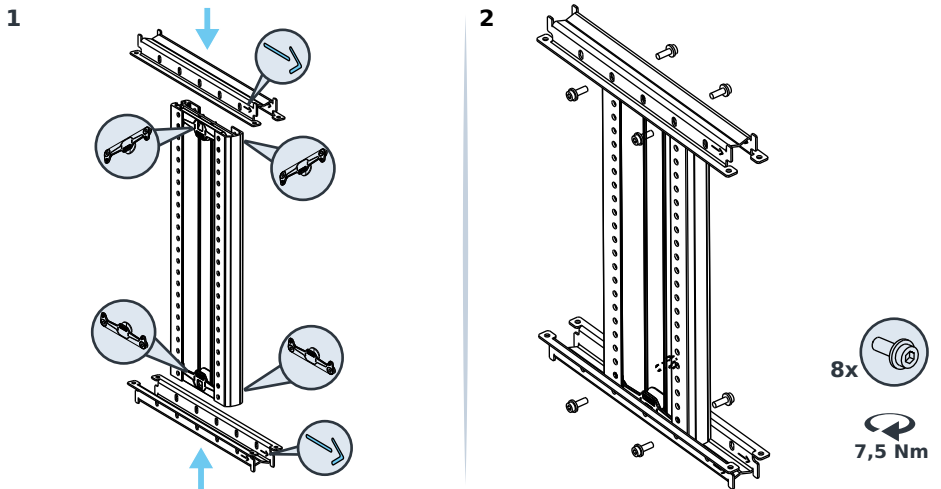

Stap 5 — Installatie van de tussenprofielen

1

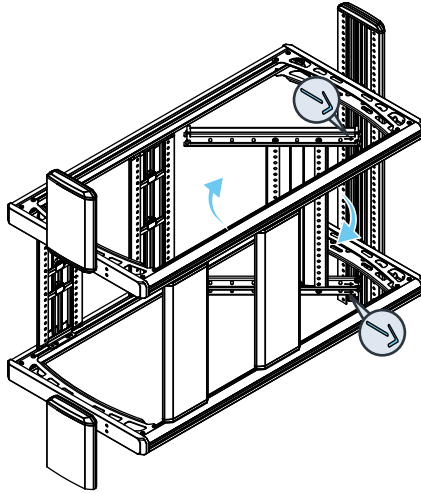

2

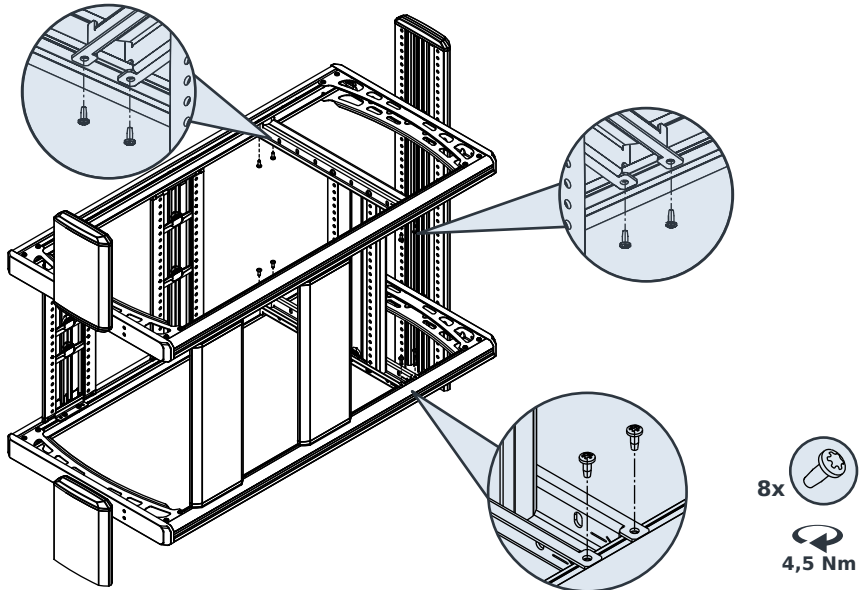

Stap 6 — Installatie van de laden

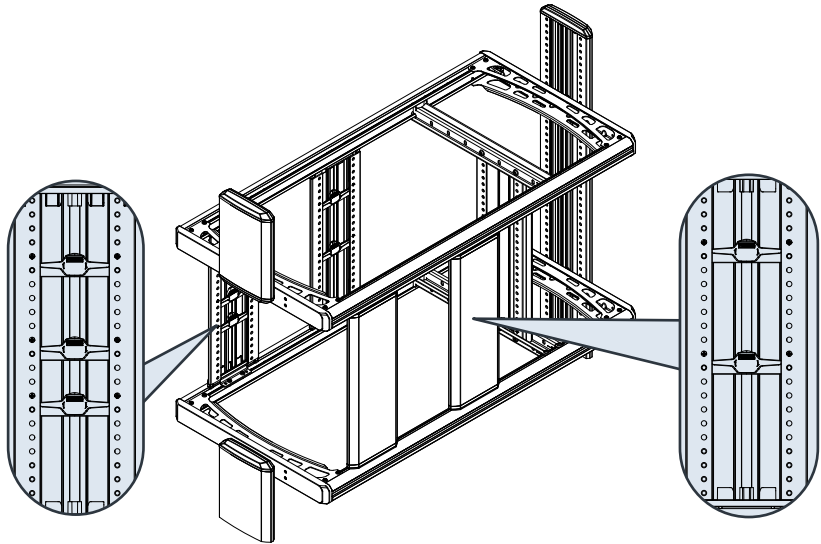

1

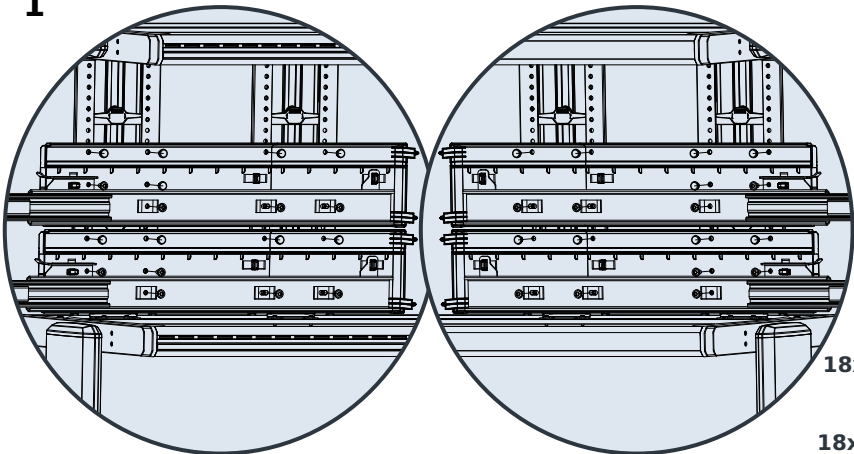

18x



18x



Stap 6 – Installatie van de laden

2

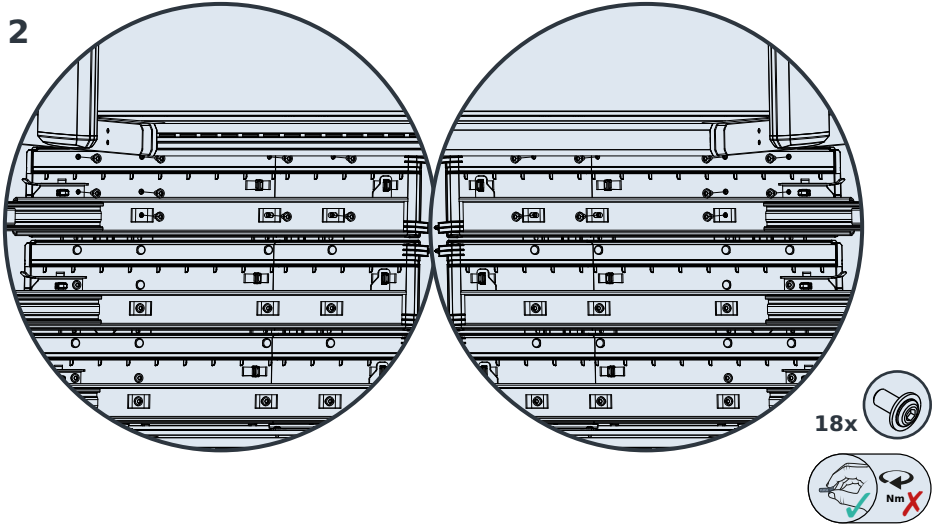

3

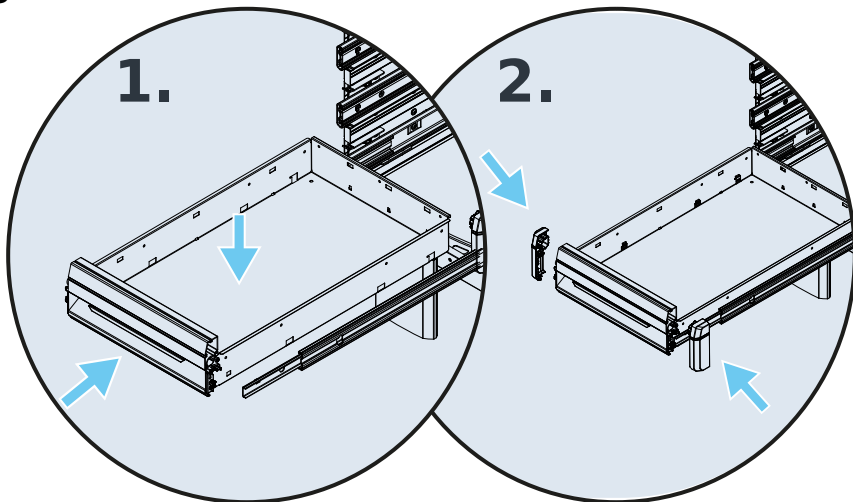

Stap 6 – Installatie van de laden

4

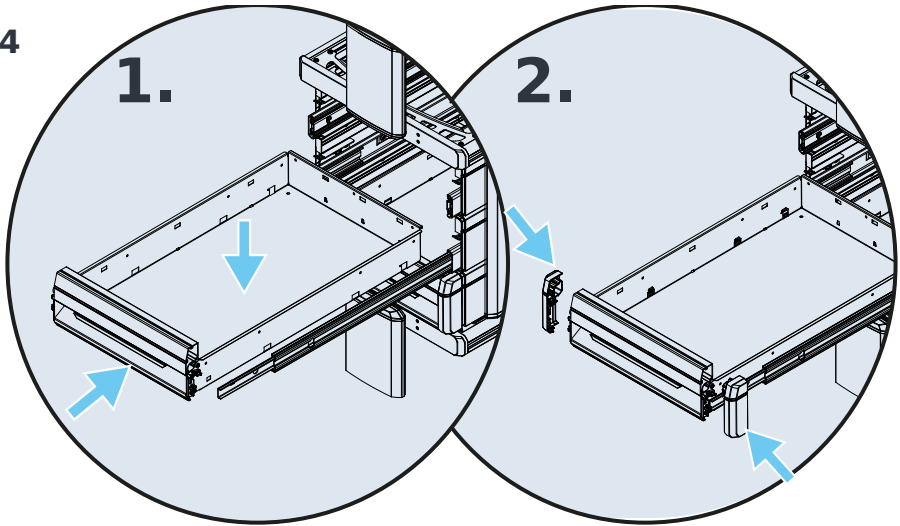

5

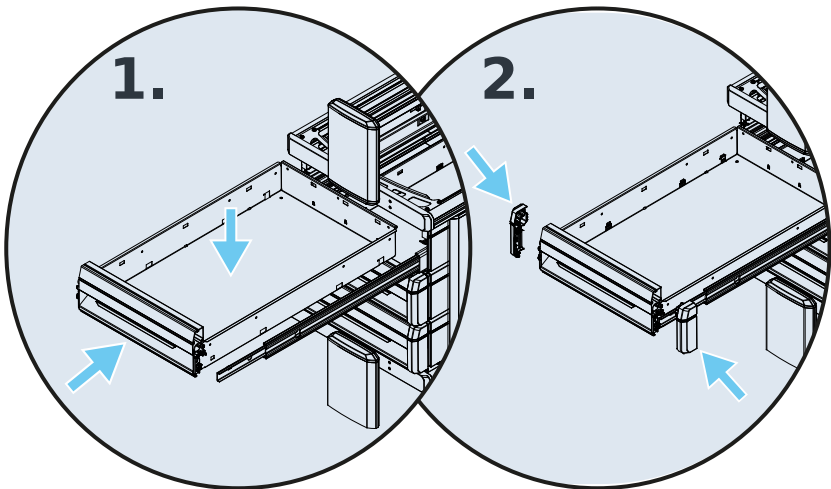

Stap 7 – Installatie van de achterwand

1

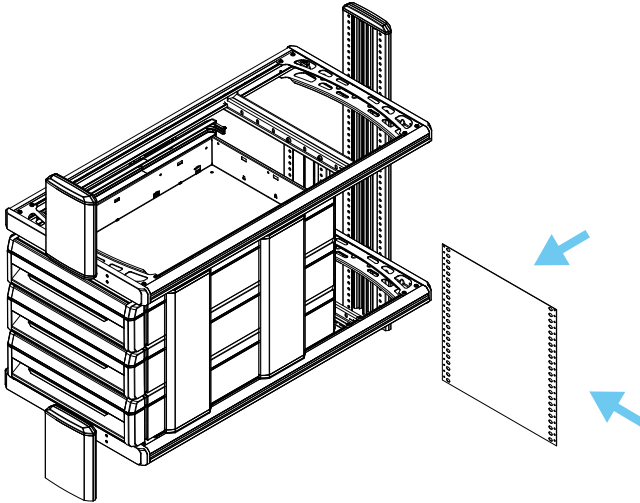

2

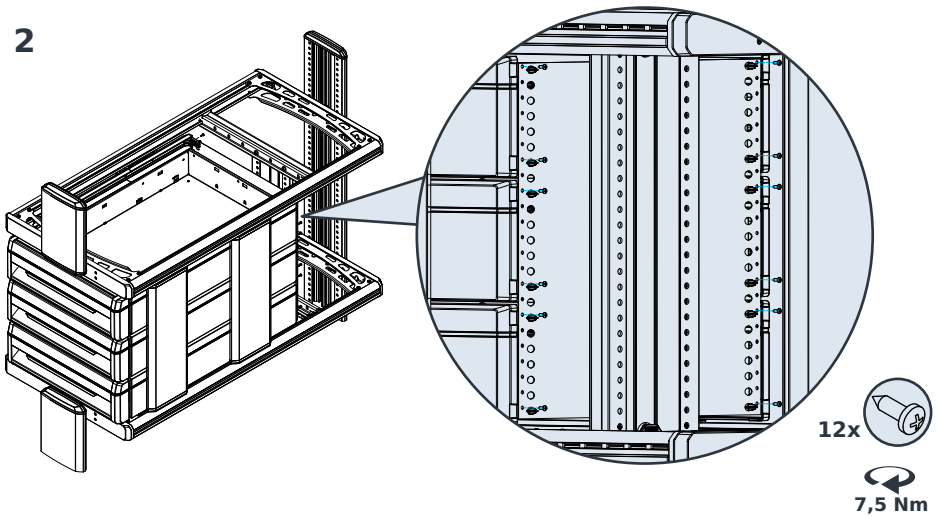

Verbindingsstappen begrijpen

EcoFIX — Wat is dat?

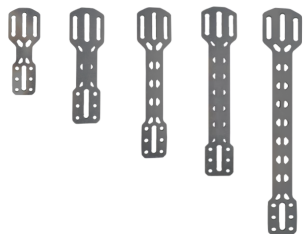

Het voertuiginterieur is met behulp van EcoFIX (EFI) aan de voertuigwand bevestigd. EFI is er in verschillende uitvoeringen. Om het voertuiginterieur met de voertuigwand te verbinden, moeten de EFI overeenkomstig de volgende regels worden gebogen.

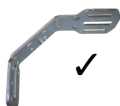

Regel

Een EcoFIX mag op meerdere plaatsen gebogen worden, maar ...

- ... maximaal 45° op één plaats.
- ... maximaal eenmaal op één plaats.
- ... de buigradius moet minimaal 4 mm zijn.

Regel

Een EcoFIX mag maximaal 90° worden getordeerd.

Regel



Bevinden zich na de inbouw van de EcoFIX in het voor de gebruiker vrij toegankelijke gedeelte. Zo moeten de randen van de EcoFIX met een beschermend profiel (art.nr.: KU100720) worden afgedekt.

EcoFIX aan het voertuiginterieur verbinden

Afhankelijk van de configuratie kan op verschillende elementen van het voertuiginterieur worden verbonden.

- Direct aan het profiel,
- direct aan het legbord,
- met behulp van een achterwandprofiel,
- met behulp van UniFix.

Direct aan het profiel

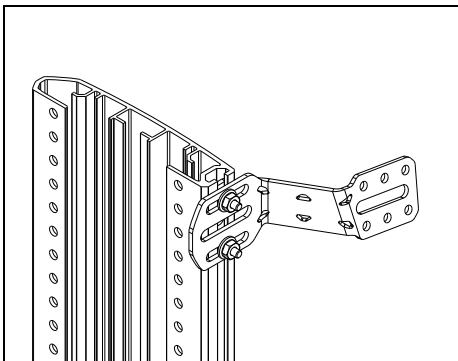

1

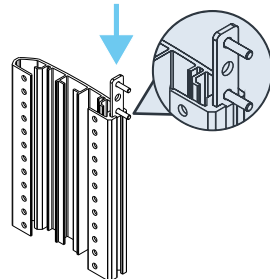

2

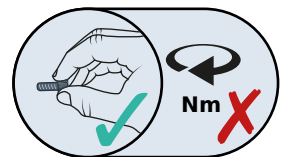
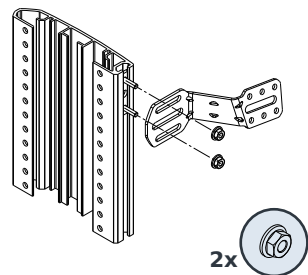

Direct aan het legbord

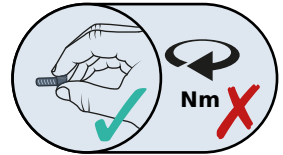
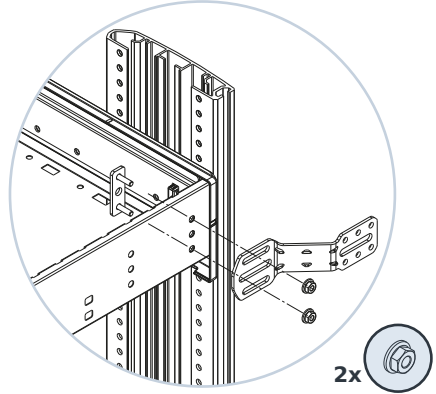
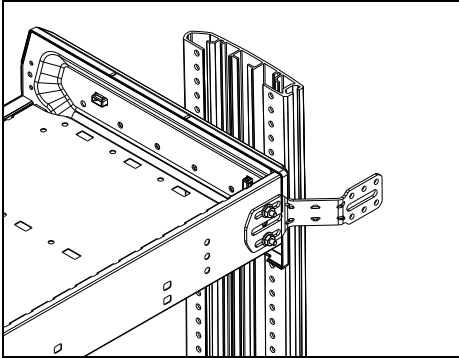

Met behulp van een achterwandprofiel

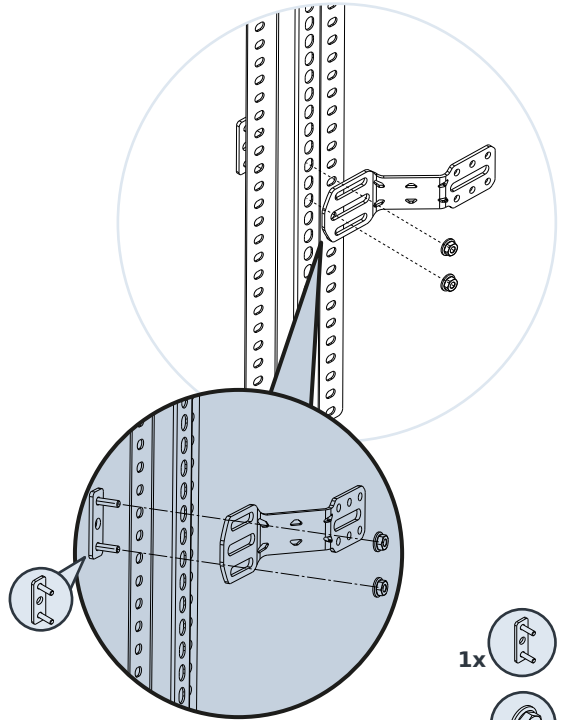
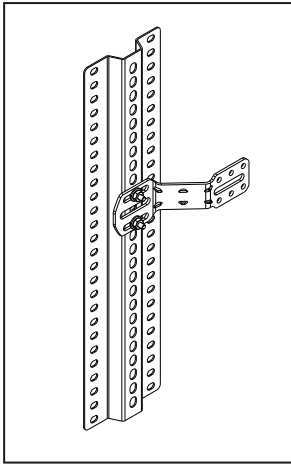

M6 x 20

M6

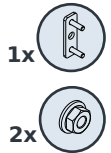

1x

2x



Nm

Met behulp van UniFix

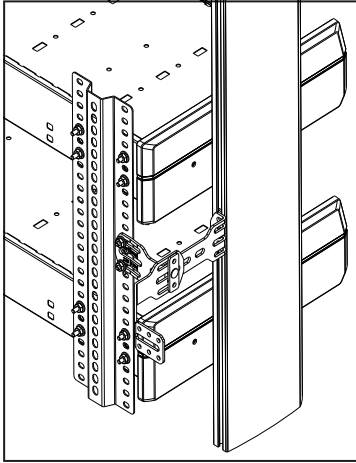

1

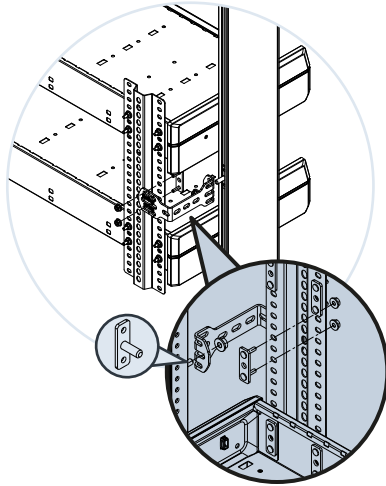

- 1x
- 1x
- 1x
- 2x

- M6 x 20
- M6
- M8 x 25
- M8

2

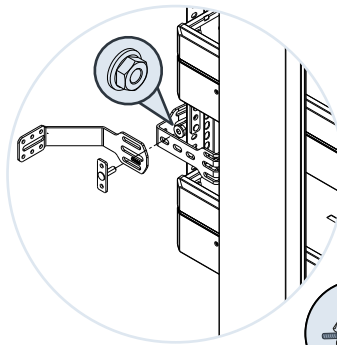

- 1x
- 1x



Achterwandprofiel bevestigen

Er zijn vier mogelijkheden om het achterwandprofiel aan de voertuiginrichting te bevestigen.

- Achterwandprofiel aan legborden,
- achterwandprofiel aan frame boven,
- achterwandprofiel aan frame onder,
- achterwandprofiel aan werkblad legbord.

Achterwandprofiel aan legborden

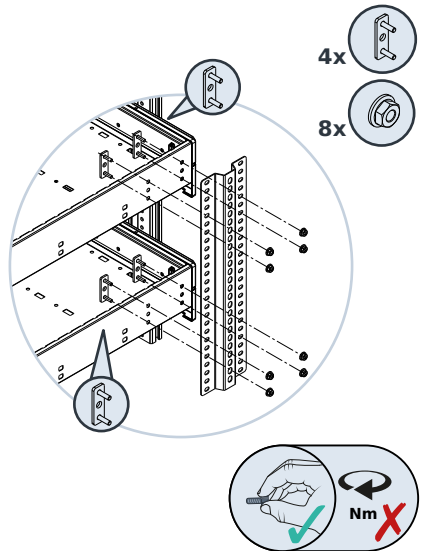
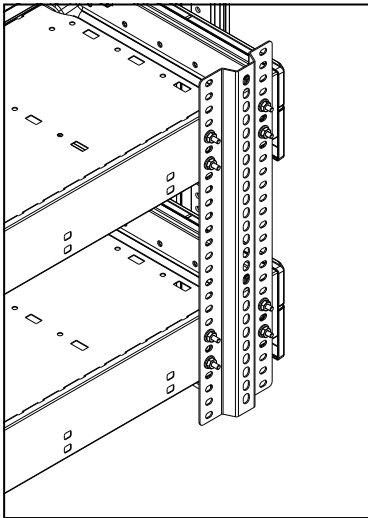



M6 x 20

 M6

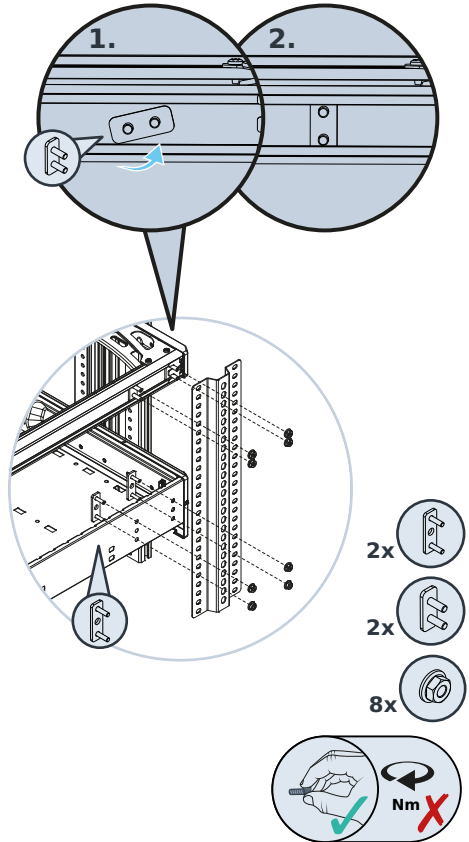
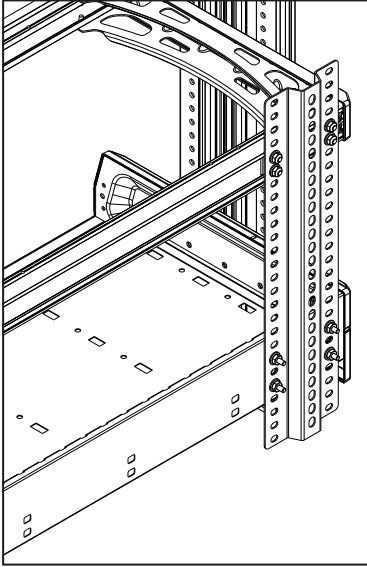
Achterwandprofiel aan frame boven

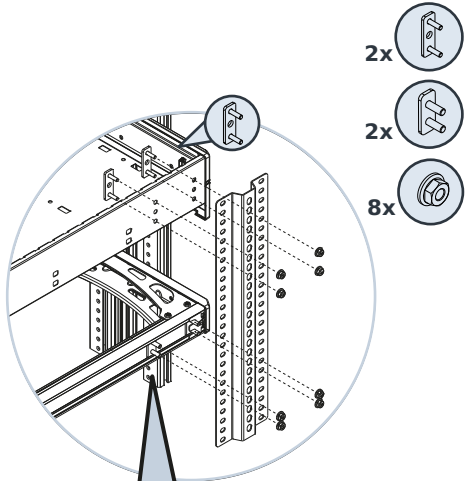
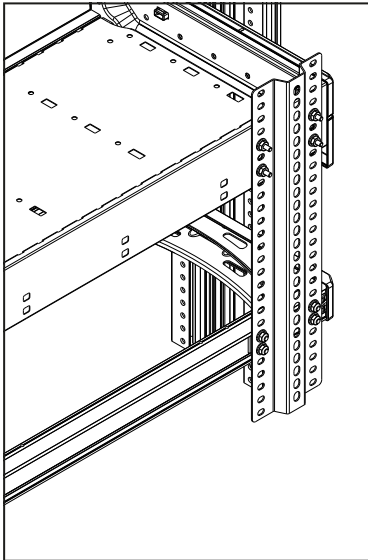

Achterwandprofiel aan frame onder



- 2x
- 2x
- 8x

- M6 x 20
- M6 x 20
- M6

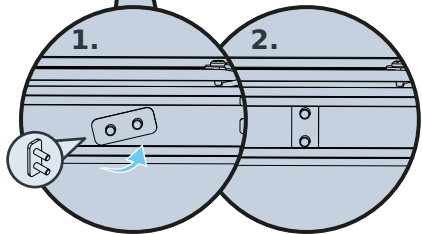

Achterwandprofiel aan werkblad legbord

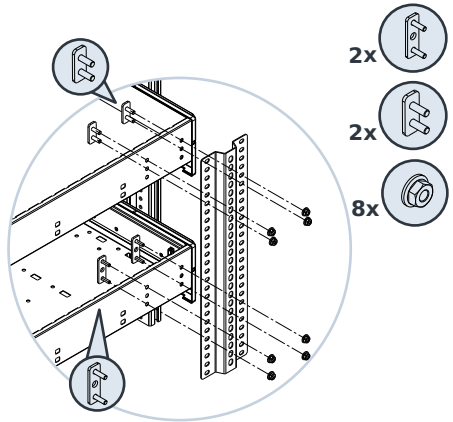
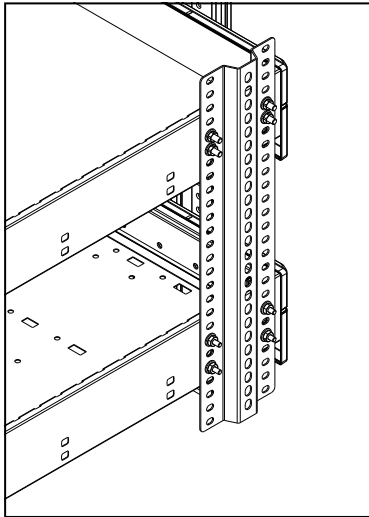

Achterwandprofiel uitbreiden

Afhankelijk van de configuratie kan het achterwandprofiel uiteenlopend worden uitgebreid.

- Achterwandprofiel verbinder
- Achterwandprofiel dieptesprong

Achterwandprofiel verbinder

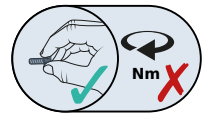
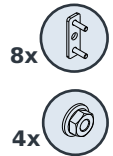
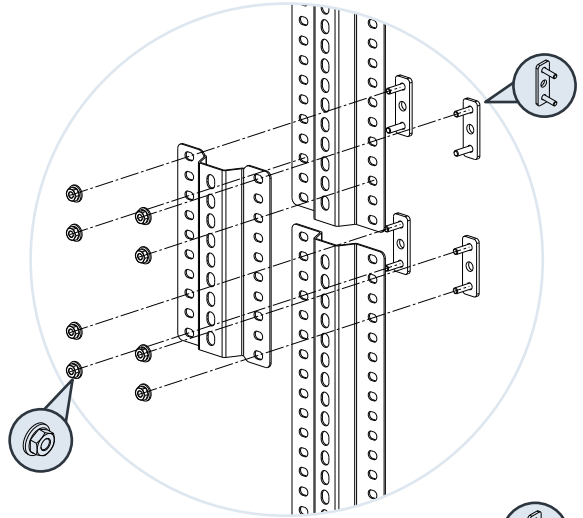
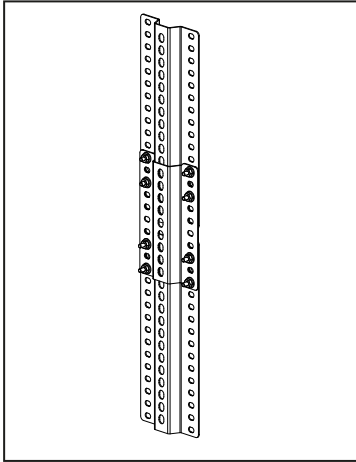

Achterwandprofiel dieptesprong

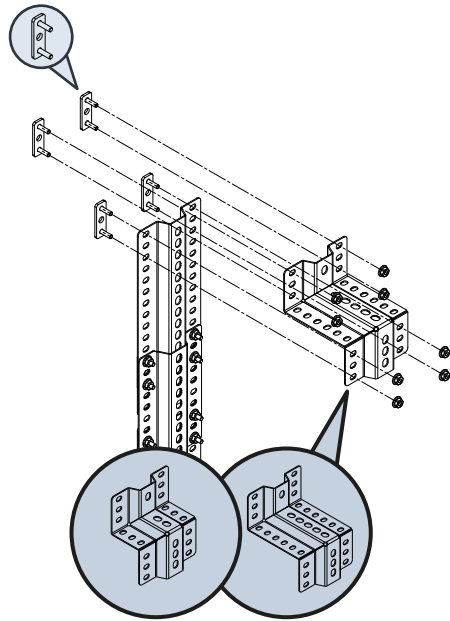
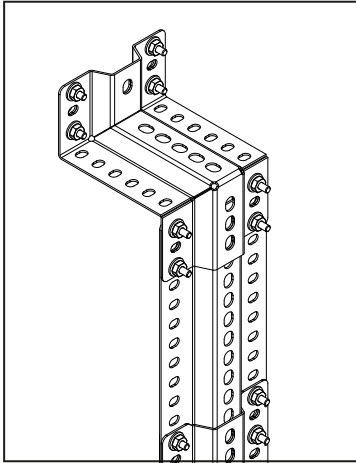

EcoFIX aan de voertuigwand verbinden

Er zijn twee mogelijkheden om de EFI met de voertuigwand te verbinden.

- a) Blinde klinknagels,
- b) montageplaat.

Regel Voor zover mogelijk is, heeft verbinding met behulp van montageplaten de voorkeur boven bevestiging met blinde klinknagels.

Blinde klinknagels

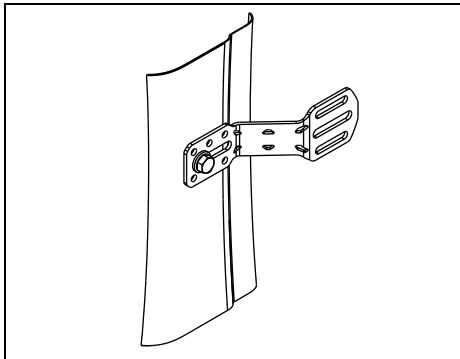

1

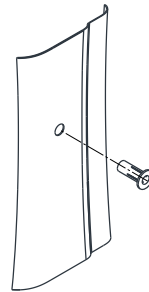

2

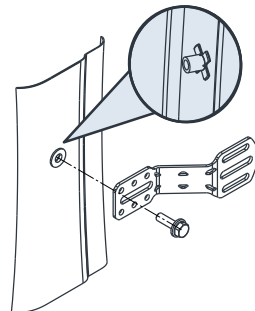

M8 x 29

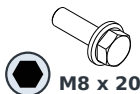

M8 x 20

LET OP

Materiële schade door boren

- Neem de waarschuwing in acht in het hoofdstuk "Voertuiginterieur verbinden".

Opmerking:

- Hiervoor is een gat van $\varnothing 11,2$ mm nodig.
- Gebruik een reeds bestaand gat in de carrosserie (oorspronkelijk gat) of boor een gat.

Montageplaat

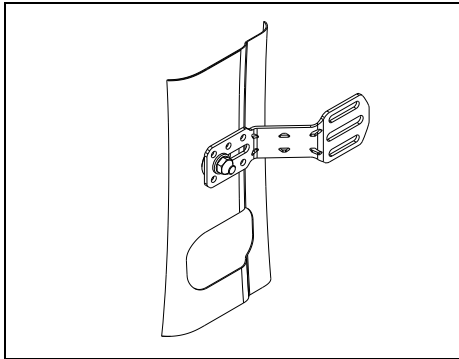

1

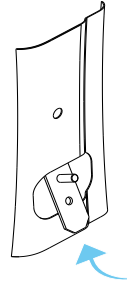

2

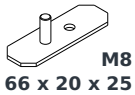
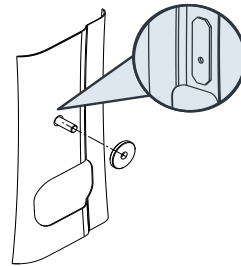

66 x 20 x 25

M8



90 x 30 x 25

M8



M8



M8

LET OP

Materiële schade door boren

- Neem de waarschuwing in acht in het hoofdstuk "Voertuiginterieur verbinden".

Opmerking:

- Voor deze bevestiging is voldoende holle ruimte achter de dragende elementen nodig. Zonder deze holle ruimte kunnen de montageplaten niet worden geplaatst.
- Hiervoor is een gat van $\text{Ø } 8,5 \text{ mm}$ nodig.
- Gebruik een reeds bestaand gat in de carrosserie (oorspronkelijk gat) of boor een gat.

3

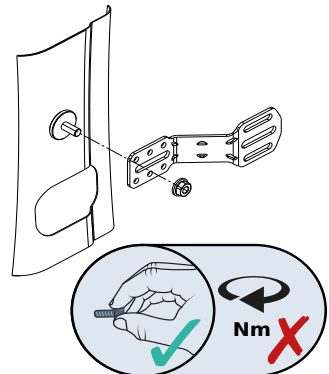

Aantal en positie bepalen

Een EcoFIX wordt in trek- of in drukrichting gemonteerd. Voor een voertuiginterieur zijn beide verbinderichtingen nodig. Afhankelijk van de rasterhoogte van het voertuiginterieur worden maximaal drie gebieden gedefinieerd. Voor deze gebieden worden hierna regels gedefinieerd.

Regel Plaats EFI in elk gebied zo hoog mogelijk.

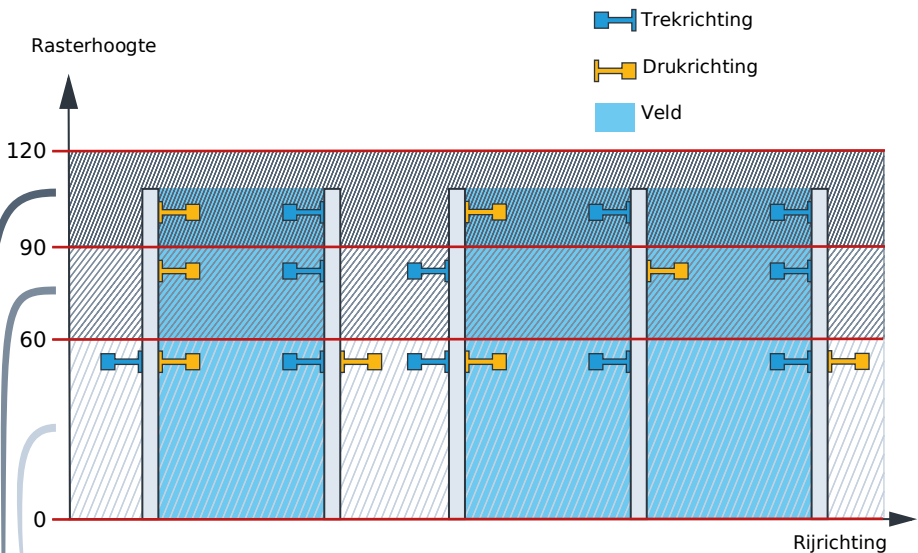

In het gebied **0 rasters tot 60 rasters** ...

- moet elk profiel via een EFI in trekrichting zijn verbonden.
- moet minimaal één profiel via een EFI in drukrichting zijn verbonden.

In het gebied **61 rasters tot 90 rasters** ...

- zou elk profiel via een EFI in trekrichting moeten zijn verbonden.
- mag maximaal één profiel zonder EFI in trekrichting zijn.
- moet minimaal één profiel via een EFI in drukrichting zijn verbonden.

In het gebied **91 rasters tot 120 rasters** ...

- zou elk profiel via een EFI in trekrichting moeten zijn verbonden.
- mag maximaal één profiel zonder EFI in trekrichting zijn.
- moet minimaal één profiel via een EFI in drukrichting zijn verbonden.

Voertuiginterieur verbinden

OPGELET

Materiële schade door boren

Componenten binnen de voertuigwand kunnen worden beschadigd.

- ▶ Op componenten letten zoals leidingen binnen de voertuigwand.
- ▶ Gebruik een boorhuls.
- ▶ Neem de richtlijn van de carrosseriefabrikant in acht.
- ▶ Bevestig uitsluitend aan geschikte plaatsen.
 - ▷ Stabiele stijlen,
 - ▷ stabiele langsboom.
- ▶ Bevestig **niet** aan instabiele tussenschakelingen of wielkasten.

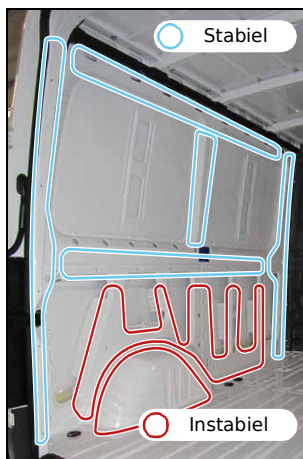

Stap 1 — EcoFIX voorbereiden

- ▶ Zoek een geschikte positie.

- ▶ Markeer de posities op het voertuiginterieur en de voertuigwand met een geschikte stift.

- ▶ Buig EcoFIX.

- ▶ Herhaal de handelingen totdat alle EcoFIX zijn voorbereid.

Stap 2 — Voertuigwand voorbereiden

- ▶ Bereid de verbindingpunten in de voertuigwand.
 - ▶ Herhaal de handelingen totdat alle verbindingpunten zijn voorbereid.
-
- ▶ Breng de verbindingpunten over op de zijwandbekleding als een zijwandbekleding in het voertuig moet worden ingebouwd.
 - ▶ Monteer de voorbereide zijwandbekleding in het voertuig.

Stap 3 — Voertuiginterieur aan voertuigwand verbinden

- ▶ Fixeer EcoFIX aan het voertuiginterieur en aan de voertuigwand.
-
- ▶ Lijn het voertuiginterieur uit.
-
- ▶ Haal de schroefbevestigingen met de volgende draaimomenten aan.

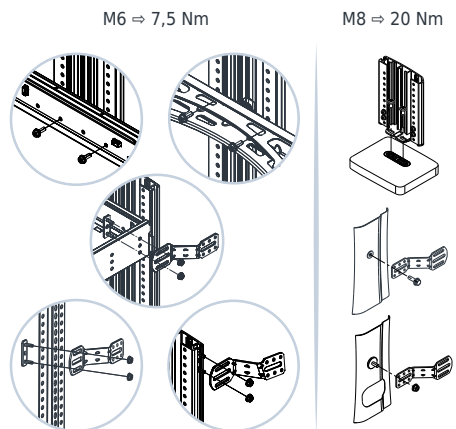

Stap 4 — Veiligheidskenmerk bevestigen

- ▶ Veiligheidskenmerk zichtbaar in de laadruimte op het verdeelschot kleven.

Opmerking: KU1014727

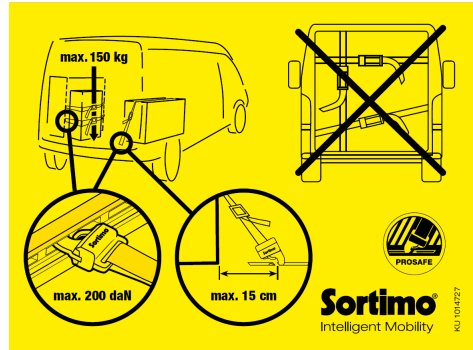

Toebehoren monteren

Uitschuifgleider boven

6000011582
6000011583
6000011584

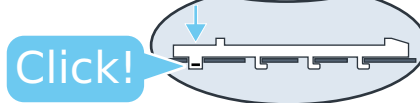
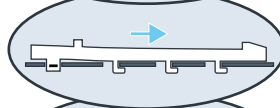
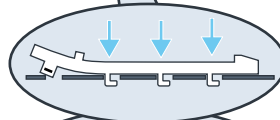
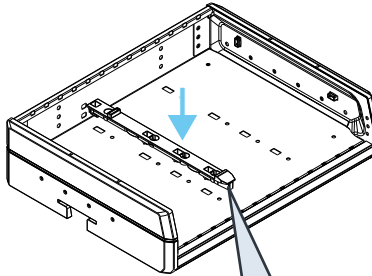
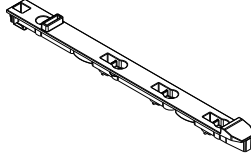
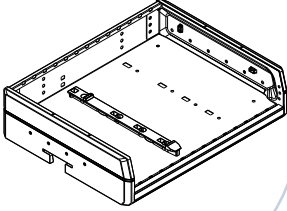

Uitschuifgeleider onder

A 1000012239
1000012241

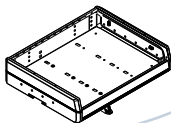

B 1000012238
1000012240

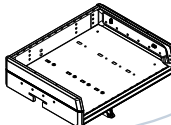

6 x 18



6 x 38

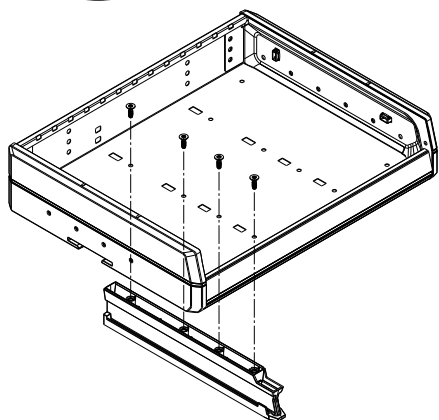
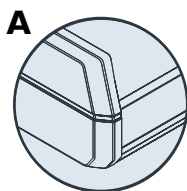
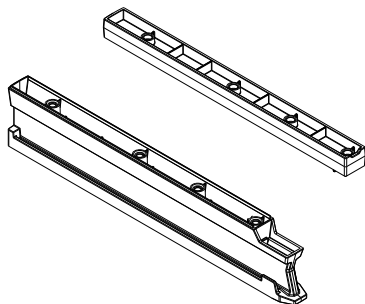

7,0 Nm

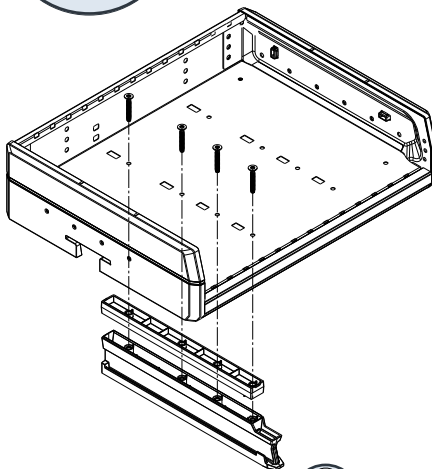
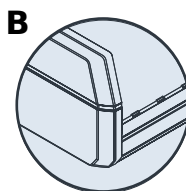

7,0 Nm

Uitschuifgleider onder 04-0 FB03

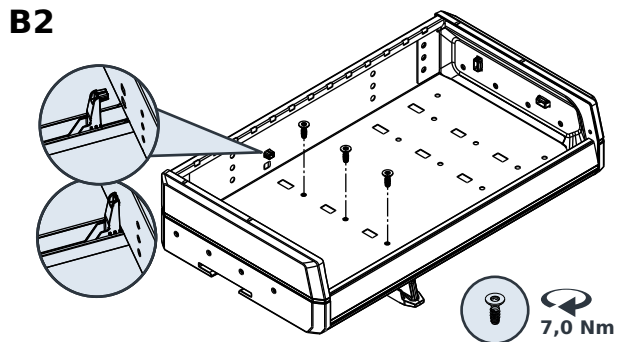
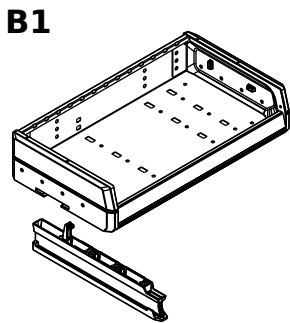
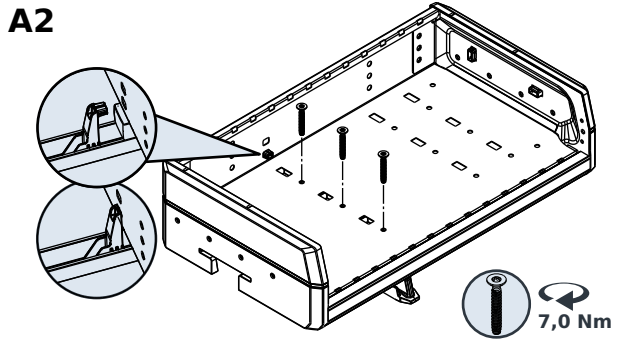
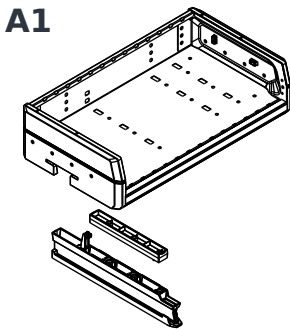
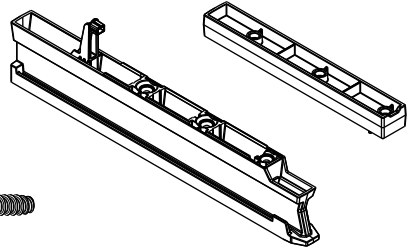
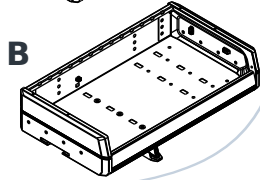
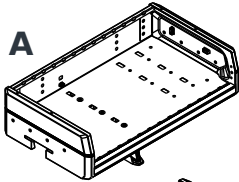

Uitschuifgeleider onder en boven

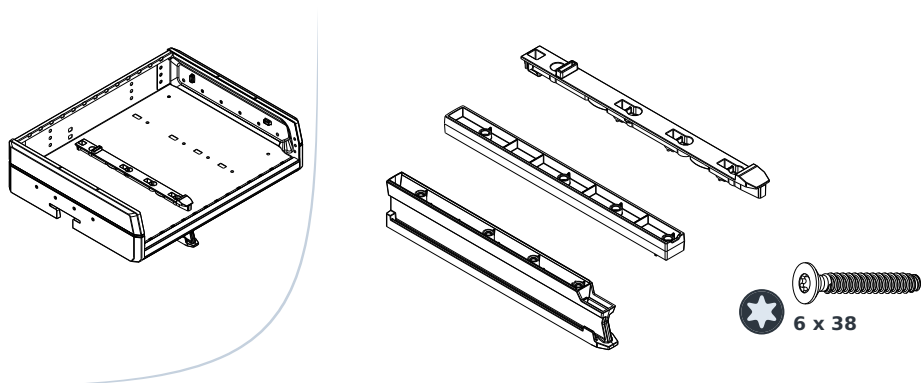

1

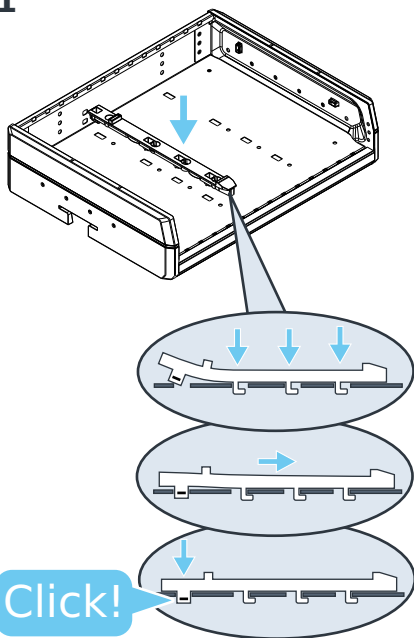

2

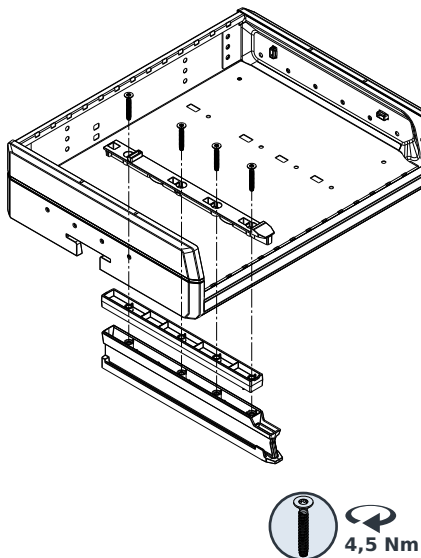

Verdeelschot voor legbord

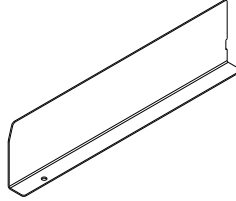
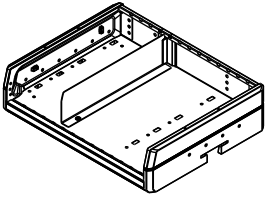

1

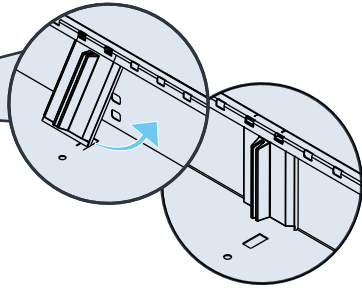
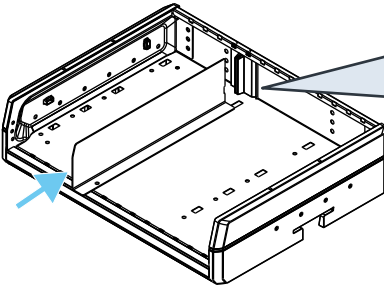

2

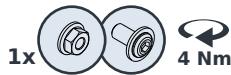
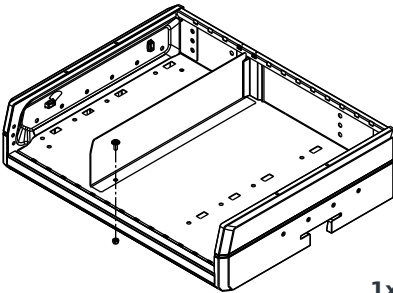

Verdeelschot voor legbord met rand

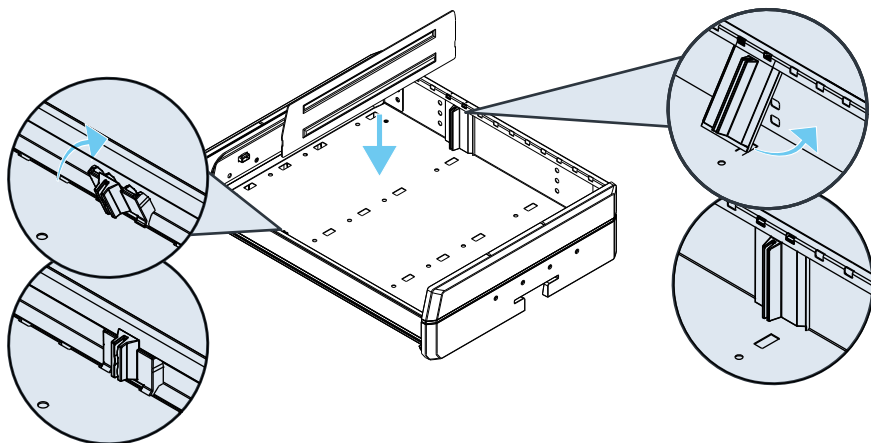
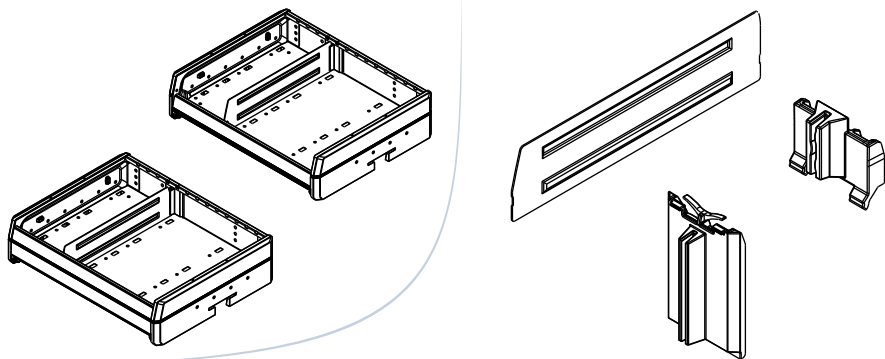

Legbord universele kast

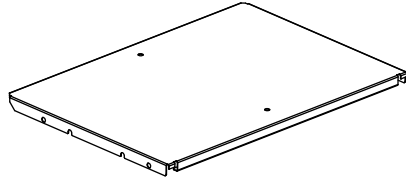
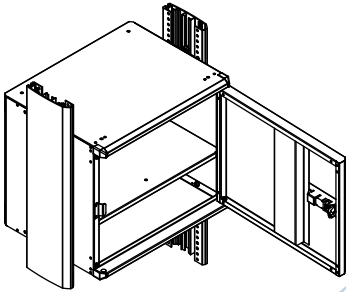

1

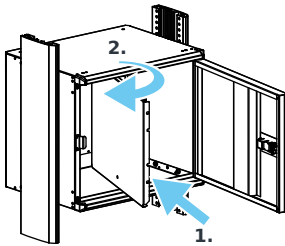

2

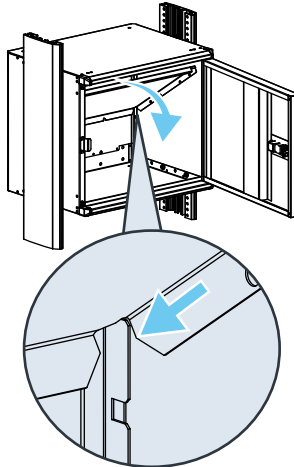

3

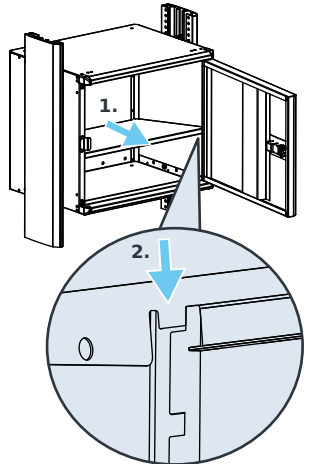

Werkblad voor legbord

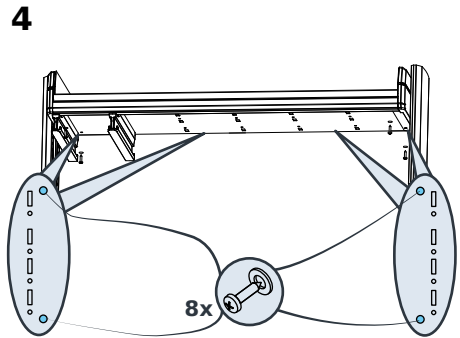
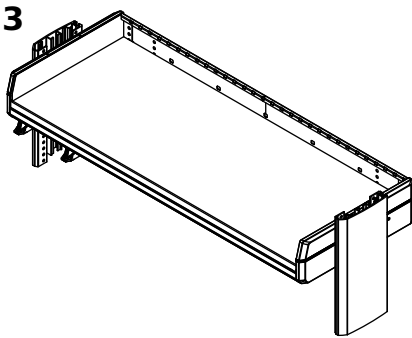
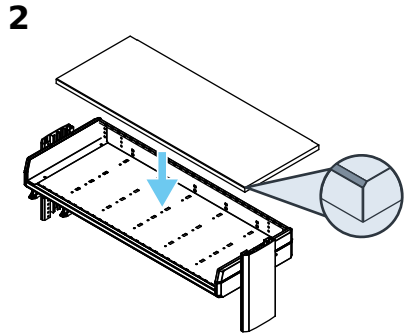
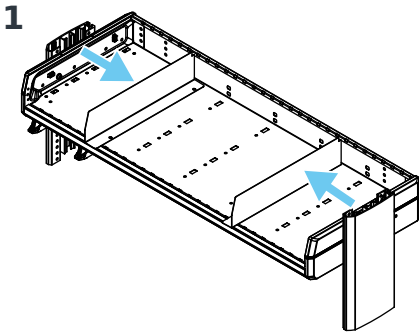
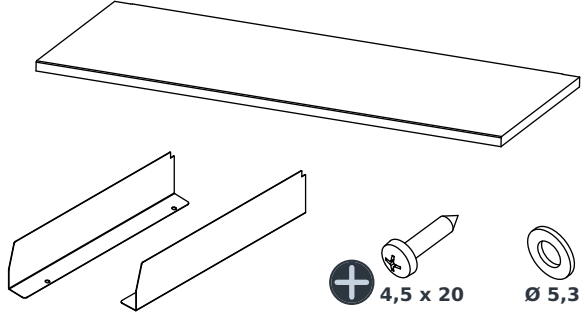
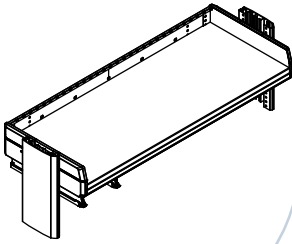

Montage van de accessoires voor het zijprofiel

Logo



1

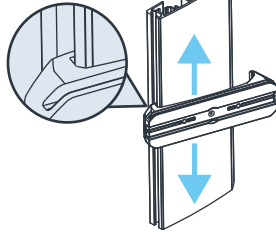

2

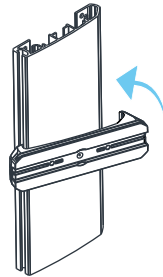

3



Aflegvak

1000012211

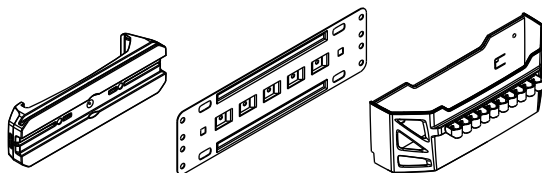
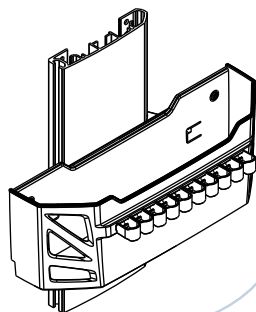

1

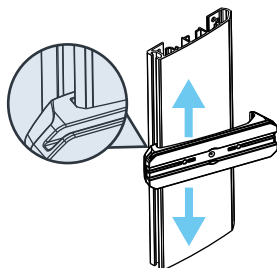

2

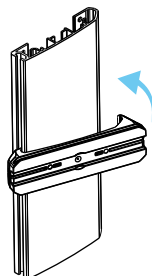

3

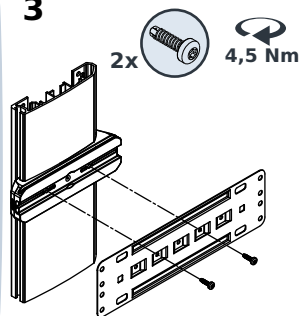

4

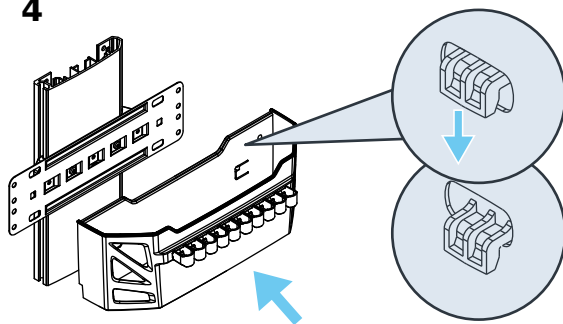

5

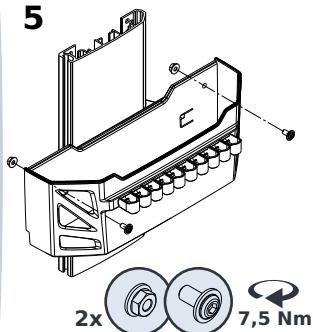

Aflegvak voor papieren

1000012208

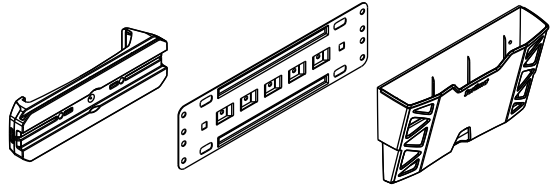
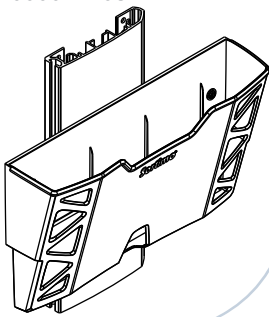

1

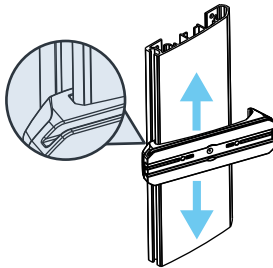

2

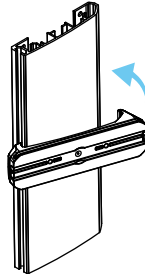

3

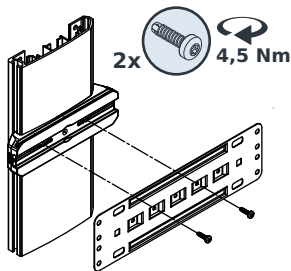

4

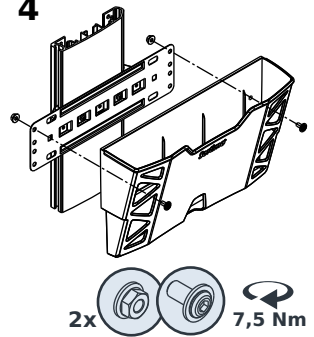

Papierhanddoek dispenser

1000012206

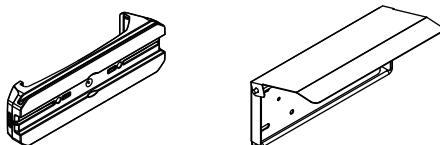
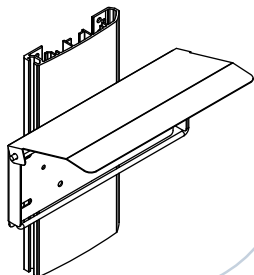

1

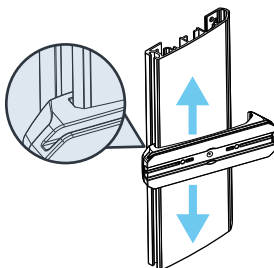

2

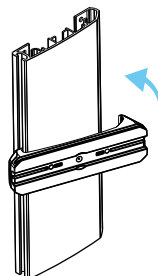

3

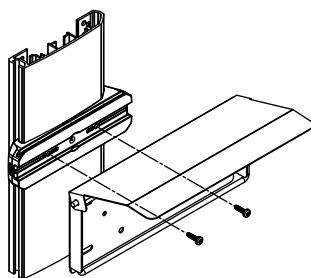

ProSafe vastzetrail

1000012755
1000012209
1000012756

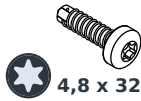
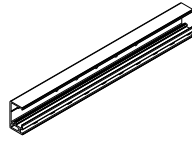
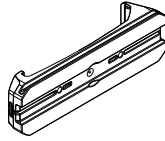
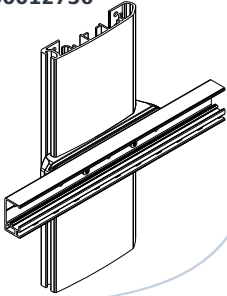

1

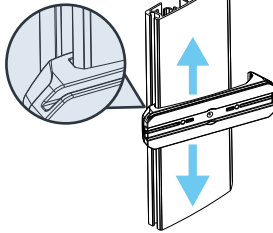

2

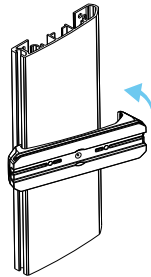

3

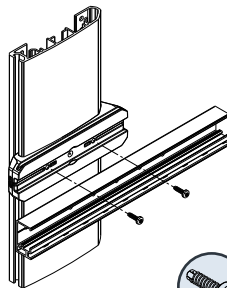

2x



4,5 Nm

Hakenstrip

1000013574
1000012210
1000013575

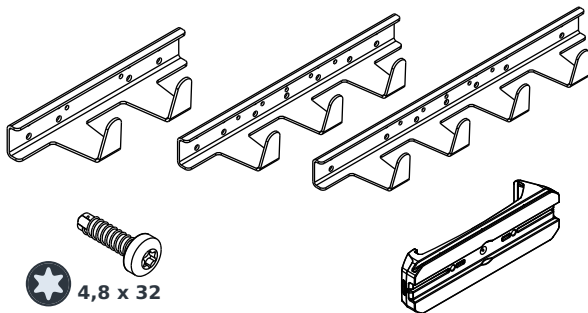
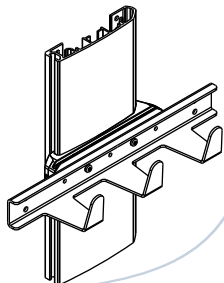

1

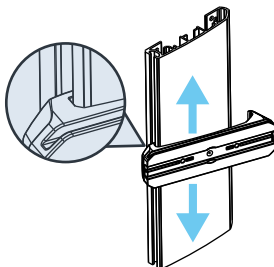

2

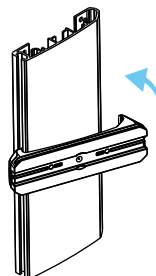

3

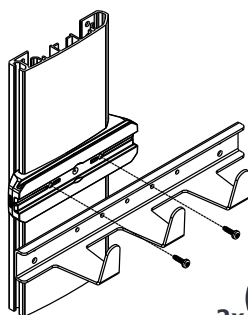

2x  4,5 Nm

Slangenhouder

1000012787
 1000012207
 1000012788

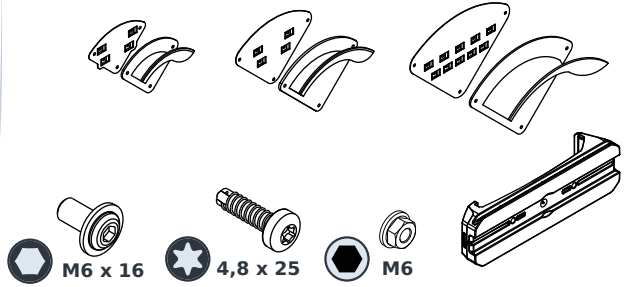
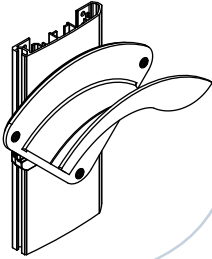

1

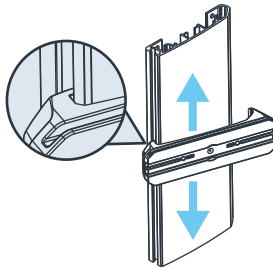

2

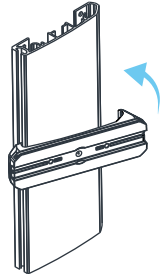

3

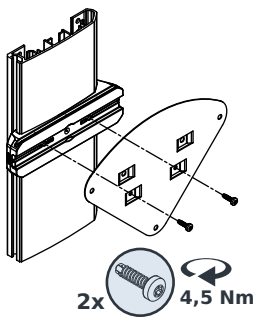

4

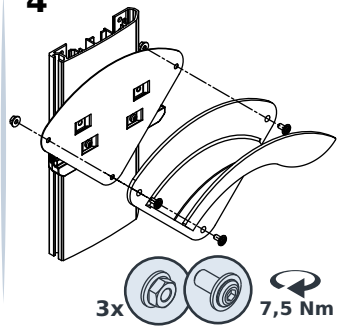

i-BOXX wandhouder

1000012904

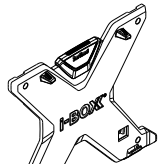
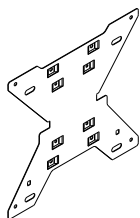
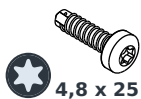
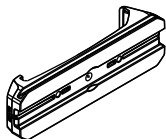
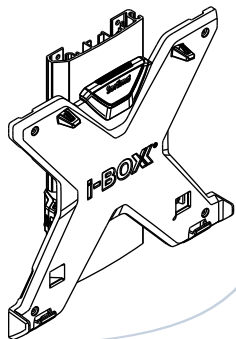

1

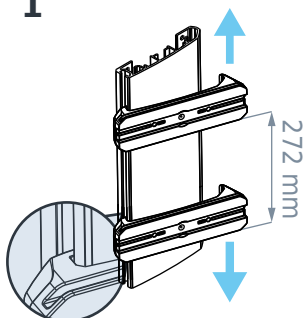

2

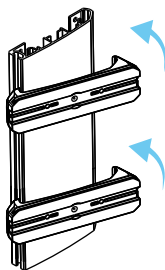

3

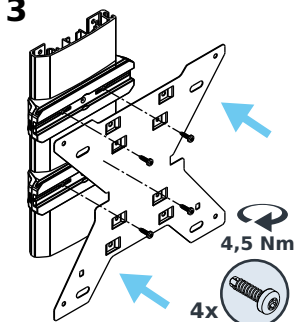

4

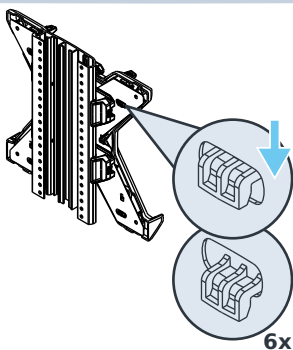
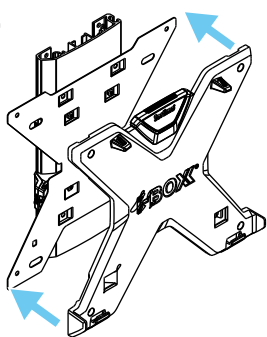

5

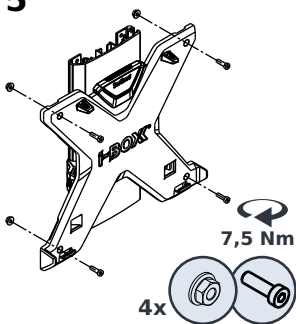

Handgreep

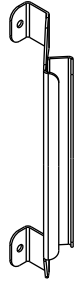
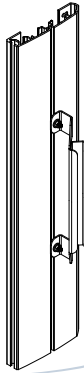

1

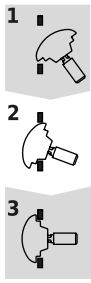
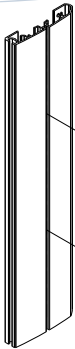

2

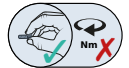
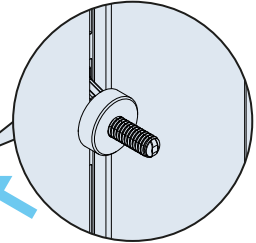

3

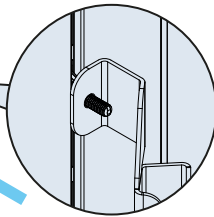
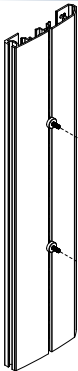

4

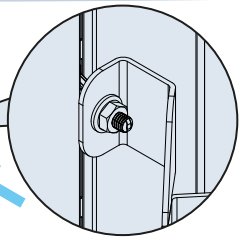
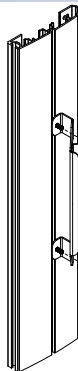

7,5 Nm



Tussenprofielaccessoires monteren

Aflegvak

1000013544

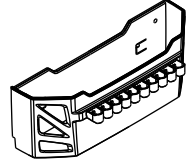
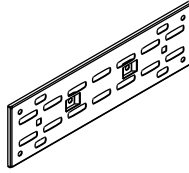
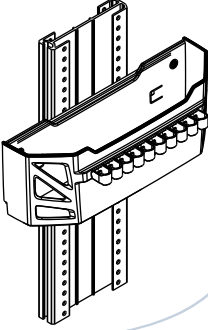

1

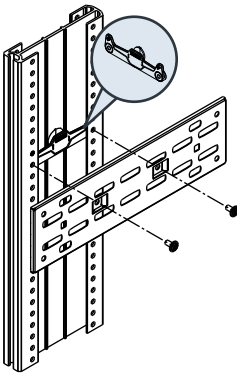

2

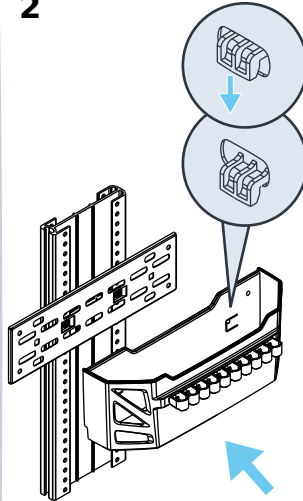

3

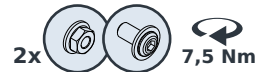
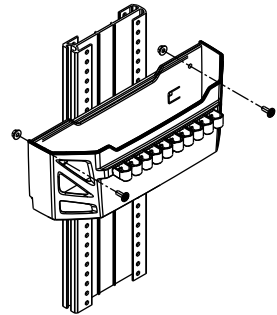

Aflegvak voor papier

1000013661

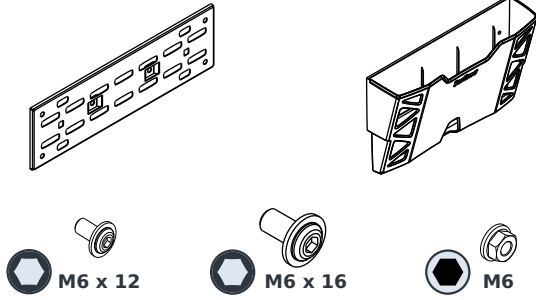
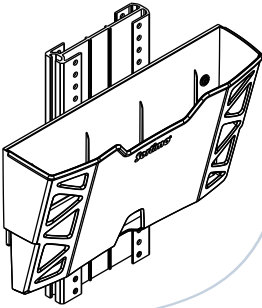

1

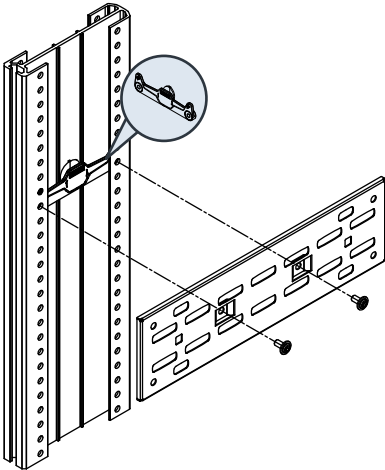

2

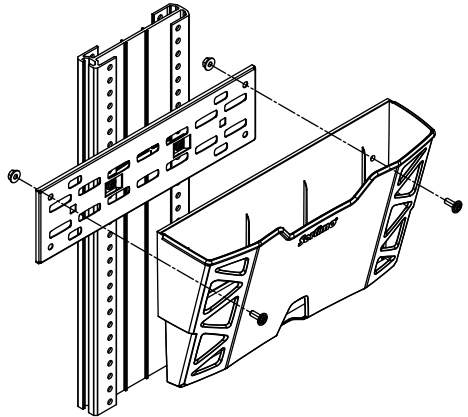

Papierrolhouder

1000013665

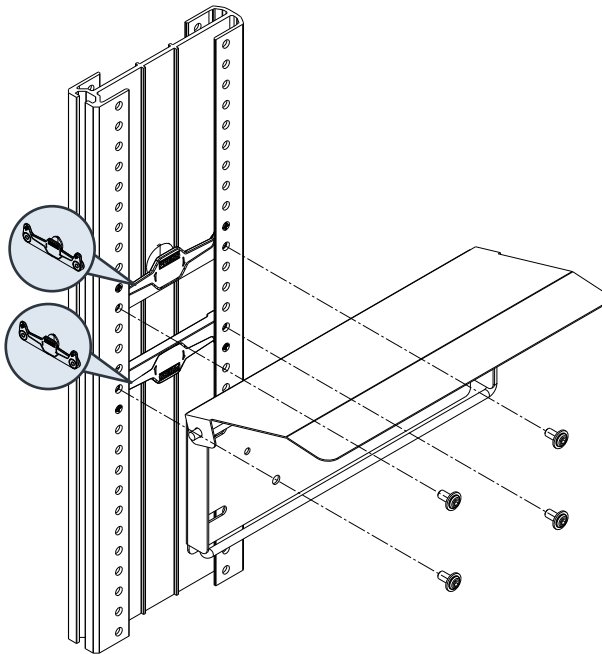
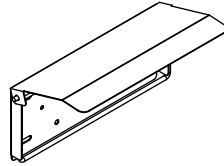
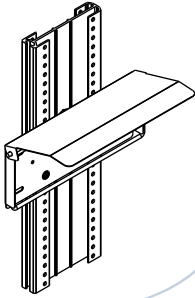

Montagerail ProSafe

1000013670
1000013671
1000013672

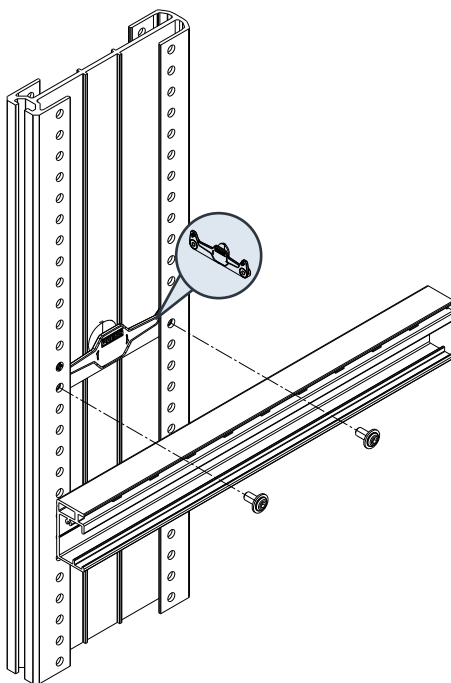
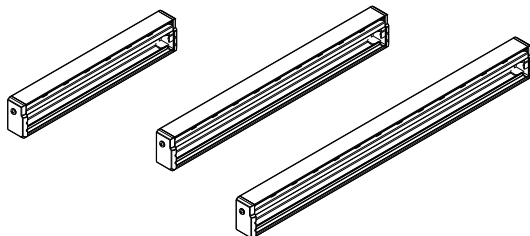
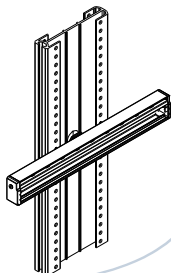

Hakenstrip

1000013662
1000013663
1000013664

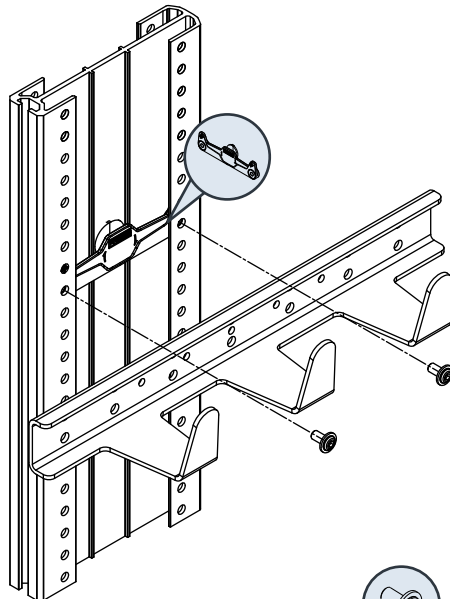
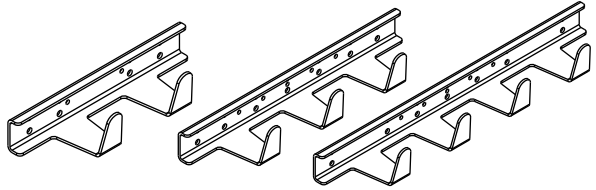
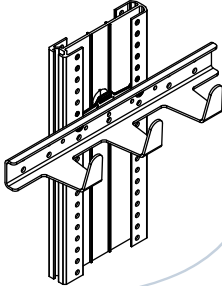

Slanghouder

1000013666
1000013667
1000013669

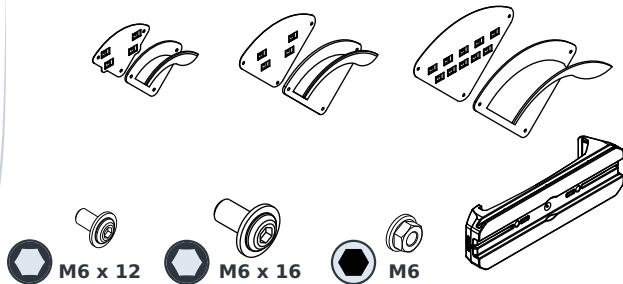
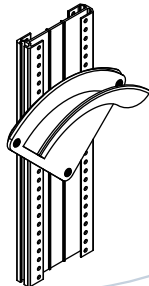

1

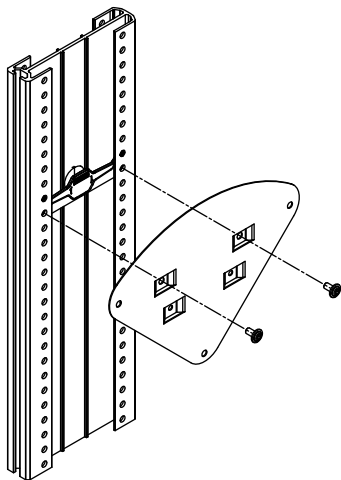

2

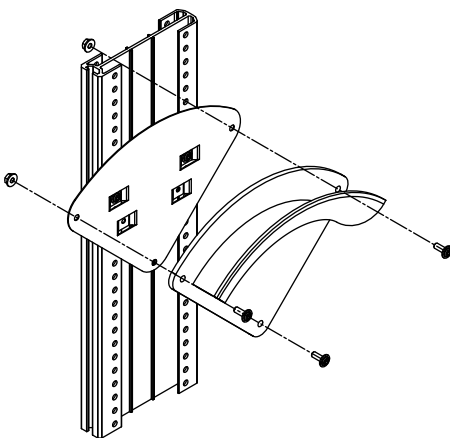

i-BOXX-wandhouder

1000013673

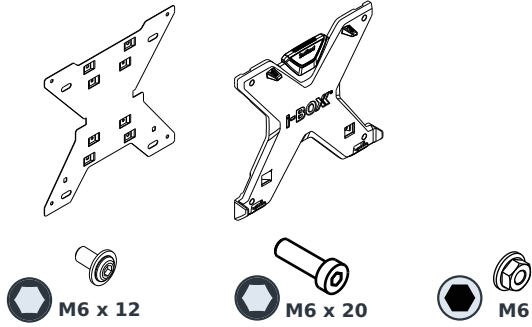
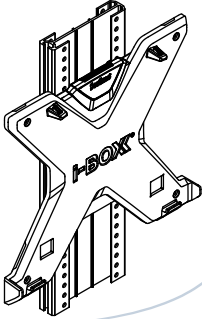

1

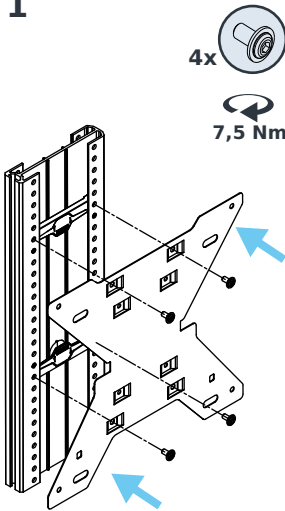

2

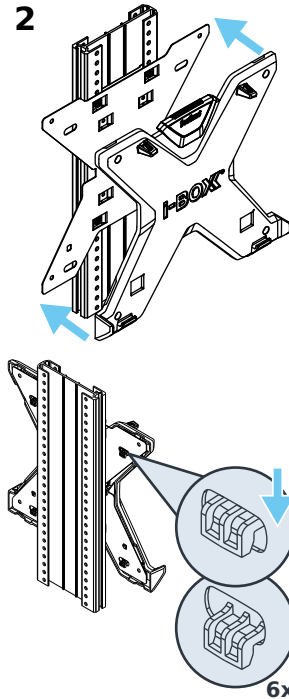

3

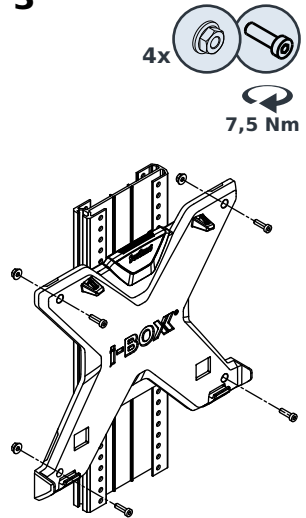

Sortimo International GmbH | Dreilindenstraße 5 | D-86441 Zusmarshausen
direct@sortimo.de | www.sortimo.com